

STATE OF MAINE DEPARTMENT OF TRANSPORTATION



BRUNSWICK CUMBERLAND COUNTY US ROUTE 1 (PLEASANT STREET) AC-STP-1911(900)X PROJECT LENGTH : 5 SIGNALS

PLAN LEGEND		
	Existing	Proposed
Controller with Cabinet		
Vehicular Signal Head		
Video Detection Camera		
Junction Box		
Mast Arm with Steel Pole		
Pole with Foundation		
Pedestal Post and Foundation		
Span wire or Mast Arm Mounted Sign		
Pedestrian Signal Head with Push Button and Informational Sign		
Preemption Receiver (R#)		
Preemption Confirmation Strobe		
Proposed Underground Conduit		
Proposed Wireless Interconnect Device		

INDEX OF SHEETS	
Description	Sheet No.
Title Sheet	1
General Notes	2
Overall Map	3
Traffic Signal Plans *	4-12
Interconnect Plan	13
Time Space Diagrams	14
Curb Ramp Layout Plans	15-16

* Each traffic signal plan contains a design, phasing and timing plan sheet with a supplemental major equipment, emergency preemption, overhead signs, and interconnect detail sheet.

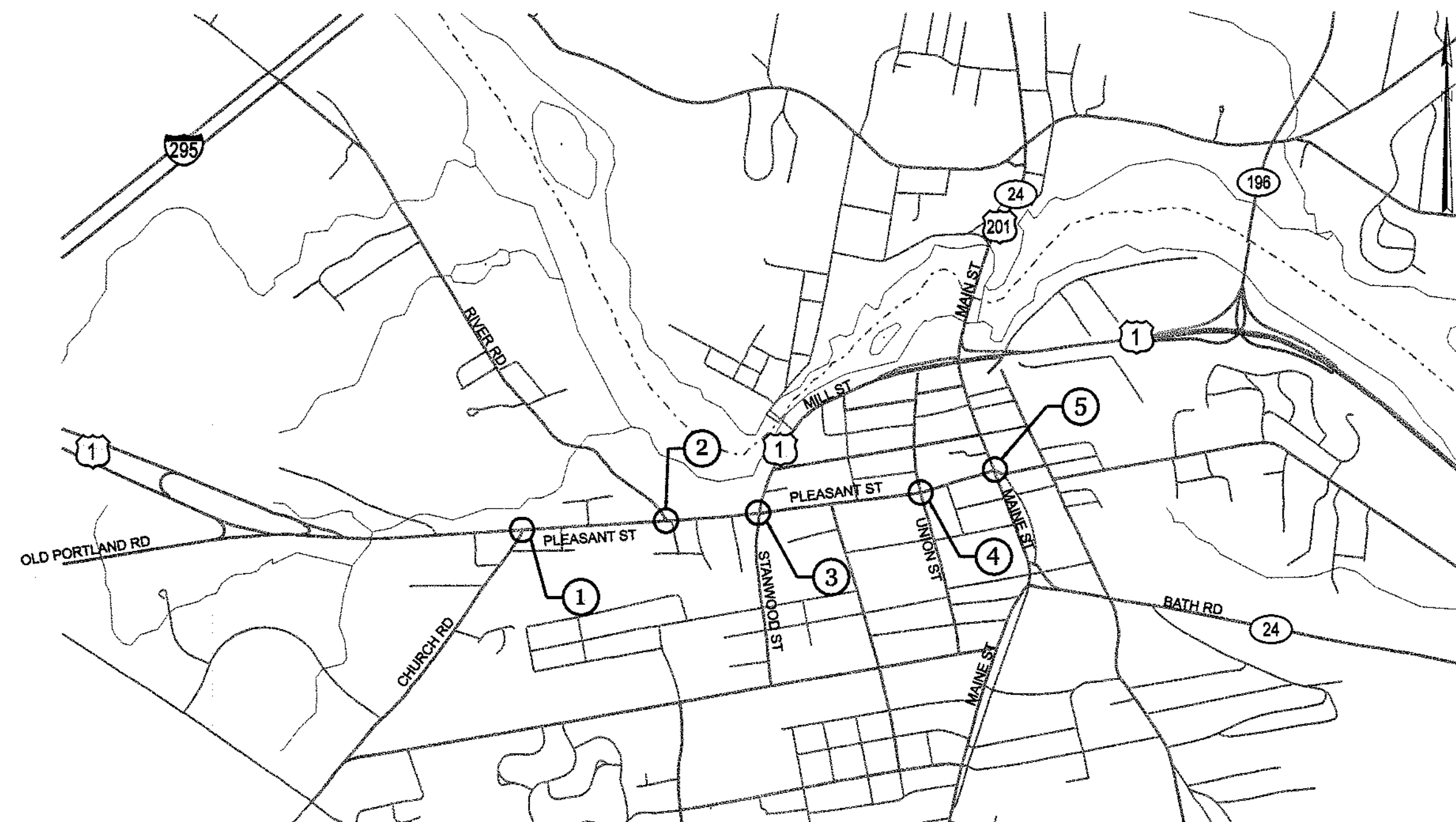

KEY:
 Project Intersection Number

TRAFFIC DATA	PLEASANT ST. W/O RIVER
Current (2010) AADT	25,600
Future (2030) AADT	28,300
DHV - % of AADT	12%
Design Hour Volume	3,100
% Heavy Trucks (AADT)	4%
% Heavy Trucks (DHV)	2%
Directional Distribution (DHV)	55%
18 kip Equivalent P 2.0	n/a
18 kip Equivalent P 2.5	n/a
Design Speed (mph)	35
Functional Class:	Principal Urban Arterial

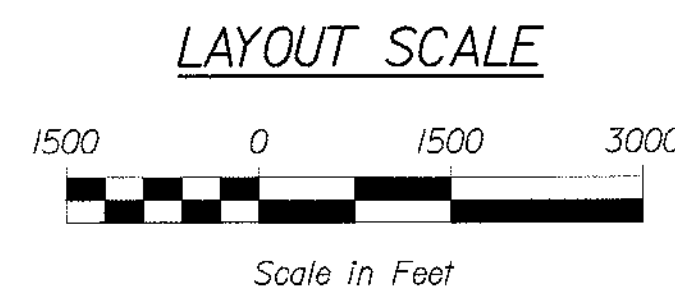

Vanasse Hangen Brustlin, Inc.

PROJECT LOCATION:	In the Town of Brunswick along a portion of US Route 1 and continuing along Pleasant Street from Church Road to Maine Street
PROGRAM AREA:	Highway Safety and Spot Improvements
OUTLINE OF WORK:	Traffic Signal Interconnection, Modernization, and other incidental work

STATE OF MAINE DEPARTMENT OF TRANSPORTATION	APPROVED	DATE
COMMISSIONER:		5/12/12
CHIEF ENGINEER:		

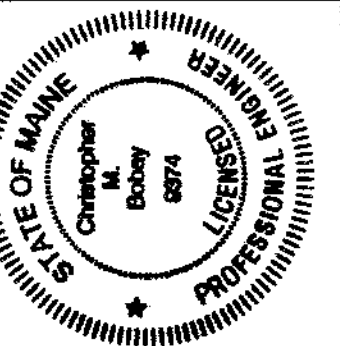

TRAFFIC INFORMATION	PROGRAM	PROJECT MANAGER	DESIGNER	CONSULTANT	PROJECT RESIDENT	CONTRACTOR	PROJECT COMPLETION DATE
		B. KEEZER	C. BOBAY	VHB			

SIGNATURE	P.E. NUMBER	DATE
	9374	4/25/2012

BRUNSWICK PLEASANT STREET
TITLE SHEET

SHEET NUMBER
1
OF 16

WIN 1911900 AC-STP-1911(900)X

Date: 4/25/2012

Username: J. ROBERT

Division:

Filename: ... \s\planset\001_5216700COV.DGN

GENERAL NOTES:

- Where noted on the plans, all new vehicular signalheads shall be equipped with relocated LED lenses 12 inches in diameter and equipped with new 5-inch louvered back plates.
- All new signalheads shall be fix mounted to most arms with Astrobrackets or mounted to most arm poles with bracket arms or span wire mount and tethered as indicated on plans.
- The bottom of the housing of new signal faces shall be at least 16 feet but not more than 19 feet above the pavement grade at the center of the roadway. For pole mounted signalheads, the bottom of the housing shall be mounted at least 8 feet but not more than 19 feet above the sidewalk, or if there is no sidewalk, above the pavement grade at the high point of the road
- Two copies of as-built plans, wiring diagrams, box prints, and equipment manuals shall be left in each of the controller cabinets.
- The Contractor is responsible for finding exact locations of existing utilities prior to construction. The Contractor shall contact Dig-Safe and appropriate authorities prior to any subsurface activities.
- Traffic signal work shall be completed in a manner and order that will cause the minimum disruption to traffic.
- The Engineer and MaineDOT shall have the right and authority to determine the acceptability of work and materials in progress or completed and shall have the right to reject any work or materials which do not conform, in its sole opinion, to the plans or specifications.
- All signing, signal and striping materials and placement shall conform to the MaineDOT standard specifications, supplemental specifications and standard details and with the Federal Highway Administration "Manual on Uniform Traffic Control Devices" (MUTCD) dated 2009, as amended.
- Any relocations or adjustments of existing utility facilities will be made by the respective utilities in coordination with the work of the Contractor.
- Contractor shall be responsible for obtaining any necessary opening permits.
- All existing driveway accesses shall be maintained at all times.
- The Contractor shall provide the Engineer, MaineDOT, and the Town of Brunswick with a schedule of work for constructing the traffic improvements at least two weeks prior to the commencement of work.
- All materials schedules shown on the plans are for general information only. The Contractor shall prepare his own material schedules based upon his plan review. All schedules shall be verified in the field by the Contractor prior to ordering materials or performing work.
- All non-paved areas disturbed during construction shall be loamed and seeded, unless otherwise directed by the owner. All paved areas disturbed during construction shall be repaired by the Contractor. Costs for repair of disturbed areas shall be incidental to other contract items.
- Equipment

Contractor Furnished Equipment - The traffic signal controllers and various other equipment items shown on the plans shall be furnished and installed by the Contractor. The traffic signal controllers supplied under this contract shall be NEMA TS-2, Type 1 or 2 and shall have the capability of supporting NTCIP protocols. Traffic signal controllers shall support a wireless (radio) communication system.

If approved as a bid alternate the system shall employ an IP-based communications network to and from a central system control computer. The equipment supplied and installed shall be capable of upload to and download from each of the system's traffic signal controller databases, remotely access local intersection reports, remotely access processed vehicle detector data, and provide real time intersection status to support graphical local and system maps.

The Contractor shall be solely responsible for providing the project with working and fully configured controllers for each intersection, delivery and complete set-up of the central system (if approved as bid alternate), installation of the central and local intersection communications interface, and coordination with the information technology (IT) personnel at the Town of Brunswick Police Station or other location as directed by the Town. The Contractor is further responsible for any local wiring at the Town of Brunswick's system computer location, system (if approved as bid alternate) Start-up and System Loading, Acceptance Testing, Training and System Maintenance. In addition, the Contractor shall furnish and install and/or expand the existing light-based emergency vehicle preemption system compatible with the preemption emitters owned by the Town of Brunswick Fire Department.

The Contractor shall be solely responsible for furnishing and installing all other equipment to include vehicle traffic signals, pedestrian signals, pedestrian push buttons and signs, wireless communications systems, emergency vehicle preemption receivers, emergency vehicle preemption confirmation lights, video detection cameras, video-based presence detection sensors, field wiring, and all other equipment necessary to provide complete and operational traffic signal systems. The Contractor shall be aware of and conform to all details for the material specifications in Special Provision 718.

16. Foundations

When new conduit is extended or installed into new mast arm signal foundations, Contractor shall break into existing foundation to expose the existing conduit bend. New conduit shall be attached to existing conduit bend.

In lieu of installing new controller cabinet foundations with new, extended or modified conduit connections to the existing signal system, the Contractor may at his discretion and upon approval by the Engineer form and pour a new controller cabinet foundation suitable to accommodate a P-type cabinet around any existing controller foundation. If this option is chosen, the Contractor must meet the following conditions:

- Minimum 6-inches on the vertical faces and 4-inches of new concrete on top above the old concrete. This may mean chipping down a few of inches of old concrete.
- Existing anchor bolts must be cut below the new finished top surface.
- New anchor bolts shall be drilled into the new concrete foundation.
- Strengthen the new concrete jacket with adequate reinforcement, following standard details for new concrete installation.
- Meet American with Disabilities Act (ADA) requirements.

17. Start-Up and System Loading

The system supplier shall initiate complete system operation from the controller and system timing schedules shown on the plans or data supplied by the Engineer and shall initiate detectors and system detector logging operation at the direction of the Engineer. After the supplier has initiated system operation and detector logging, the system shall be run for a continuous 7-day initial operational testing period. If any major functions of the system fail to operate during this testing period, as determined by the Engineer, the supplier shall correct or repair the system and the continuous 7-day testing period shall be restarted. At the completion of a successful 7-day testing period, the supplier shall advise the Engineer that the system is ready for the Start-up Phase. Within 7 days of completion of the initial testing period, and notification to the Resident Engineer with on-site assistance from the supplier's engineer, will begin loading the system for full coordinated operations. After coordination has been initiated and run for approximately two weeks, the Engineer shall evaluate system operation and make adjustments as necessary. The Supplier's engineer does not need to be on-site during this period, but must be available by telephone or by demand on-site as needed. Any major system malfunctions encountered during this testing period shall be corrected by the supplier, and the test restarted. During this period the Engineer may make modifications to the system timing parameters, but this will not cause restarting of the testing period. At the completion of the coordination testing period the system will be deemed ready for final Acceptance Testing as described below. Testing of controllers per section 718.07 is not required.

18. Acceptance Testing

Upon completion of the 7 day coordination testing period, the Engineer shall evaluate the on street system operation through the closed loop system master. If the remote signal system is approved as a bid alternate, it is expected that the complete system shall operate fully functional at the Town of Brunswick Police Department and the remote locations for a period of 30 consecutive days without malfunction. Minor malfunctions of inoperability not the fault of the Contractor, as judged by the Engineer, are not included in the 30-day period. If the system fails to operate as intended or the supplier's claims, the malfunction shall be corrected by the Contractor at its cost and a new 30-day testing period shall begin. This process shall continue until a completely operable system is demonstrated for a consecutive 30-day period.

Acceptance testing must demonstrate to the Engineer's reasonable satisfaction that the hardware and licensed software function in accordance with the specifications, requirements, through-puts, functionalities, performance criteria or other benefits stated in documentation, promotional materials, proposals, and/or demonstrations given to MaineDOT and the Town of Brunswick.

19. Training (If approved as Bid Alternate, Item 643.81)

The Contractor shall provide 3-days (18 hours minimum) of hands-on system training classes, which shall cover the general operations and maintenance of the traffic signal system. The training shall be designed for the primary local jurisdiction personnel (Town of Brunswick) and MaineDOT personnel who will use and monitor the system. The Contractor should budget for up to 8 attendees.

Training documentation shall include operating manuals for all system equipment and components. Documentation shall also be provided, explaining the operation of all system features. Hard copies of all handouts used during training shall be distributed. The Contractor is expected to present clear and organized instruction. The initial training shall consist minimally of the following:

- System operation, system performance analysis, and revision of system operating parameters based on the analysis
- Familiarity with construction details of central office equipment (disconnect locations, cable routing etc.).
- How to enter system related commands.
- Operation of all devices.
- Generation and editing of intersection controllers.
- Uploading/downloading of intersection controller databases.
- Procedure for enabling dynamic displays.
- Explanation of the communication system.
- Basic troubleshooting procedures to isolate malfunctions.
- The Contractor shall supply a course syllabus for each proposed training day for approval by the Engineer at least 7 business days prior to the scheduled course. Each syllabus shall include a description of the topics covered, the level of detail to be covered in the class, and the number of teaching hours included in the class. The Contractor shall also supply a list of equipment, software, and manuals to be provided for the training at least 5 business days prior to the scheduled course. All training classes shall make use of the system data collected during the Start-up Phase of the project.

20. System Maintenance

The system must come with a minimum five (5) year software maintenance agreement to become effective when the proposed system has been accepted, in writing, by MaineDOT and the Town of Brunswick.

Software updates (if approved under the bid alternate) shall be provided free of charge for five (5) years from date of system acceptance. Software corrections or required modifications for proper system operation per these specifications shall be furnished to MaineDOT and the Town of Brunswick at no additional cost during the warranty period.

Hardware equipment shall be warranted for three (3) years, effective when the proposed system has been accepted, in writing, by MaineDOT and the Town of Brunswick.

Third party hardware and software licenses and warranties shall be passed to MaineDOT and the Town of Brunswick.

21. The Contractors shall replace any local intersection vehicle detection that is not functioning at any signalized intersection in the project prior to System Start-up and Loading. The Contractor shall also re-inspect each signalized intersection during the Acceptance Testing period and replace each non-functioning loop detector and certify that any remaining loop detectors are functioning properly before final acceptance is granted. The Contractor shall notify and receive authorization from the Engineer before replacing any malfunctioning loop detector.

22. Video Detection Installation - At locations where video detection cameras are proposed to be installed on mast arms, an initial six-foot vertical pipe extension shall be installed on the mast arm with the video detector mounted on the top of the extension pipe. The Engineer reserves the right to direct the Contractor to field adjust the video detector mounting height for local conditions identified during or after installation. No additional cost will be allowed for field adjusting the pipe extensions or rewiring as necessary. This work will be incidental to the Video Detection System items.

23. As payment for this work, the Contractor shall submit a lump sum bid per intersection and in addition a lump sum bid for wireless interconnection and a lump sum bid for proposed video based traffic presence detectors which are to be connected to the intersection for local vehicle detection. Work shall be paid for as outlined in Special Provision 64.3.

24. If the traffic signal control system is approved as a bid alternate, media converters shall be provided and remote communications through the wireless communications system established at those intersections containing existing video based vehicle detection for remote monitoring at the Town of Brunswick Police Department. Payment for the media converters and setup shall be incidental to the Traffic Signal Control System.

25. Salvage Rights: MaineDOT shall have first rights to all equipment removed or replaced by the project (contact Mike Delois at 207-624-3625). The Town of Brunswick shall have second salvage rights to all equipment not claimed by MaineDOT. The Contractor shall carefully remove and store all equipment claimed by either MaineDOT or the Town of Brunswick at a central location on site for retrieval by MaineDOT or the Town of Brunswick. The storage area shall be secure and all control equipment removed that has computer chip technology shall be stored in an interior heated environment.

Any equipment not claimed by either MaineDOT or the Town of Brunswick for salvage shall be removed from the site by the Contractor and disposed of in a manner acceptable to the Engineer.

26. The Contractor shall be responsible for submitting RED-LINE AS-BUILT drawings of the final work to the Engineer. Those drawings shall be on a clean set of plans showing all changes or modifications to the Bid Plans.

27. The Contractor will be responsible for the relocation of power meters if required. This work will be incidental to item 643.71 as applicable to the location of the work.

28. The Contractor shall perform the work in a manner that will require the least amount of downtime to the traffic signal operations. Any police detail required (as deemed necessary by the Resident Engineer) will be paid for by the Contractor.

29. The Contractor shall remain alert for any evidence of contaminated soils. The Contractor shall employ appropriate health and safety measures to protect its workers against hazards associated with excavating and working near contaminated soils. If the Contractor encounters evidence of soil or groundwater contamination, the Contractor shall secure the excavation, stop work in the contaminated area, and immediately notify the Engineer. The Engineer shall contact the Hydrogeologist in MaineDOT's Environmental Office at 207-624-3100 and the Maine Department of Environmental Protection at 800-482-0777. Work may only continue with authorization from the Engineer.

30. The Contractor is directed to project Special Provision 718 for additional information related to the following:

- 718.12 Traffic signal control system
- 718.13 Emergency vehicle preemption system
- 718.14 Wireless interconnect system
- 718.15 Pedestrian Crossing System

Special provision 718 expands upon the information found in these general notes. As such, the more restrictive language between these general notes and special provision 718 shall govern the work to be performed under this project.

DAILY AND WEEKLY COORDINATION SCHEDULE

	MON-FRI.	SATURDAY-SUNDAY
FREE OPERATIONS	0000 - 0730 0900 - 1100 1730 - 2400	0000 - 1100 1730 - 2400
PLAN 1 75/150 SECS MORNING PEAK	0730-0900	-
PLAN 2 80/160 SECS MIDDAY/EVENING PEAK	1100-1730	1600 - 1730
PLAN 3 90/180 SECS SATURDAY PEAK	-	1100 - 1600

PROGRAM PERIODS OF OPERATION

	12	1	2	3	4	5	6	7	8	9	10	11	12	1	2	3	4	5	6	7	8	9	10	11	12		
	AM											PM					AM										
SUNDAY																3		2									
MONDAY																											
TUESDAY																											
WEDNESDAY																											
THURSDAY																											
FRIDAY																											
SATURDAY																											

FR - FREE

STATE OF MAINE
DEPARTMENT OF TRANSPORTATION
AC-STP-1911(900)X
WIN
1911900

PROJ. MANAGER	B. KEEZER	BY	DATE	SIGNATURE	P.E. NUMBER	DATE
DESIGN-DETAILED	M. GRAHAM	M. GRAHAM	4/16/12			
CHECKED-REVIEWED	J. ROBERT	C. BOBBY	4/24/12			
DESIGN-2-DETAILED						
DESIGN-3-DETAILED						
REVISIONS 1						
REVISIONS 2						
REVISIONS 3						
REVISIONS 4						
FIELD CHANGES						

PLEASANT STREET
GENERAL NOTES

SHEET NUMBER
2
OF 16

Date: 4/26/2012



Username: VHB

Division:

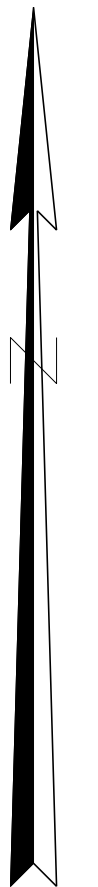
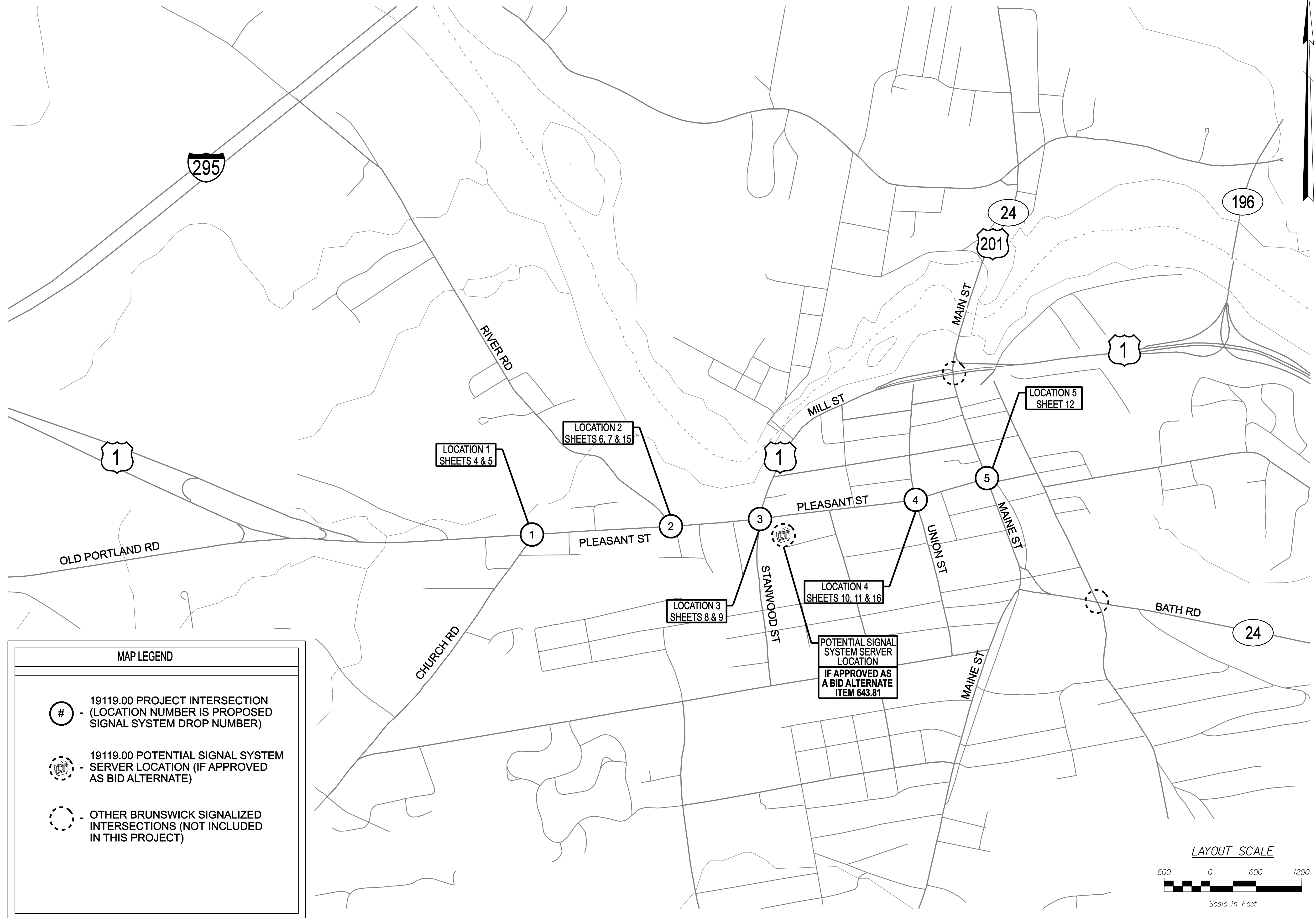
Filename: ... \planset\002_5216700NOTES.dgn



MAP LEGEND

-  - 19119.00 PROJECT INTERSECTION (LOCATION NUMBER IS PROPOSED SIGNAL SYSTEM DROP NUMBER)
-  - 19119.00 POTENTIAL SIGNAL SYSTEM SERVER LOCATION (IF APPROVED AS BID ALTERNATE)
-  - OTHER BRUNSWICK SIGNALIZED INTERSECTIONS (NOT INCLUDED IN THIS PROJECT)

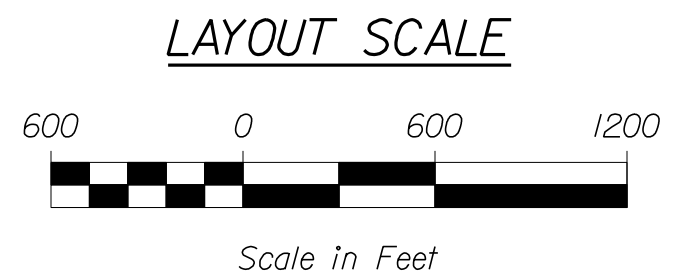

STATE OF MAINE		DEPARTMENT OF TRANSPORTATION	
AC-STP-1911(900)X		WIN 1911900	
PROJ. MANAGER	B. KEEZER	BY	DATE
DESIGN-DETAILED	M. GRAHAM	M. GRAHAM	4/16/12
CHECKED-REVIEWED	J. ROBERT	C. BOBBAY	4/24/12
DESIGN2-DETAILED2			
DESIGN3-DETAILED3			
REVISIONS 1			
REVISIONS 2			
REVISIONS 3			
REVISIONS 4			
FIELD CHANGES			
SIGNATURE		P.E. NUMBER	
DATE		DATE	
PLEASANT STREET		OVERALL MAP	
SHEET NUMBER		3	
		OF 16	

LIST OF MAJOR ITEMS

EQUIPMENT AND WORK ITEMS 643.71	QUANTITY
FURNISH AND INSTALL NEW NEMA TS2, TYPE 1 ETHERNET EQUIPPED CONTROLLER IN NEW P-TYPE BASE MOUNTED NEMA TS2, TYPE 1 MAINEDOT SPEC CABINET COMPLETE WITH ALL ANCILLARY EQUIPMENT AND WIRING INCLUDING PREEMPTION AND VIDEO DETECTION EQUIPMENT RESET FROM THE EXISTING CONTROLLER CABINET.	1
16-CHANNEL ETHERNET EQUIPPED ENHANCED MALFUNCTION MANAGEMENT UNIT	1
FURNISH AND INSTALL ONE-WAY, 3-SECTION, 12-INCH SPAN WIRE MOUNTED TRAFFIC SIGNAL HEADS WITH RETROREFLECTIVE LOUVERED BACKPLATES	4
FURNISH AND INSTALL ONE-WAY, 5-SECTION "DOGHOUSE" 12-INCH SPAN WIRE MOUNTED TRAFFIC SIGNAL HEADS WITH RETROREFLECTIVE LOUVERED BACKPLATES	2
FURNISH AND INSTALL ENVIRONMENTALLY HARDENED ETHERNET SWITCH	1
FURNISH AND INSTALL GENERATOR TRANSFER SWITCH WITH PILOT LIGHT AND ANCHOR SYSTEM	1
FURNISH AND INSTALL EMERGENCY VEHICLE PREEMPTION DETECTOR AND DETECTOR CABLE	1
FURNISH AND INSTALL SPAN WIRE MOUNT AND TETHER PREEMPTION ASSEMBLY	1
FURNISH AND INSTALL OVERHEAD MOUNTED SIGN	7
FURNISH AND INSTALL SPAN WIRE AND TETHER WIRE	210 LF
FURNISH AND INSTALL NEW SIGNAL CABLE	-
IMPLEMENT LOCAL AND SYSTEM TIMING	-

THE LISTED QUANTITIES ARE APPROXIMATE AND ARE FURNISHED FOR INFORMATION ONLY.

COORDINATION CYCLE/SPLIT/OFFSET SCHEDULE

ALL ENTRIES IN SECONDS

CYCLE LENGTH	COORDINATION MODE SET TO FIXED FORCE-OFF		
	PLAN 1	PLAN 2	PLAN 3
OFFSET (END GRN)	11	18	21
COORDINATED Ø	2	2	2
SPLIT TIME Ø1	16	16	16
SPLIT TIME Ø2	34	44	49
SPLIT TIME Ø3	25	20	25
SPLIT TIME Ø4	0	0	0
SPLIT TIME Ø5	0	0	0
SPLIT TIME Ø6	50	60	65
SPLIT TIME Ø7	25	20	25
SPLIT TIME Ø8	0	0	0

COORDINATION NOTES:

- OFFSET IS REFERENCED TO THE END OF THE COORDINATED PHASE.
- COORDINATION TO OPERATE BY TIME-OF-DAY (SEE SHEET 2 FOR DAY PLAN SETTINGS).
- PHASE 7 IS A DUMMY PHASE TO BE SET WITH SPLIT TIMES FOR NTCIP COMPLIANCE.

DETECTOR SCHEDULE

	DETECTOR				DETECTOR CARD IN VEHICLE DETECTION RACK				
	PLAN ID	STREET	DIRECTION	LANE	Ø	TYPE	SLOT NO	DETECTOR NO	CHANNEL
CAMERA V1									
CAMERA V2									
CAMERA V3									

DETECTOR NOTES:

CONTRACTOR SHALL COMPLETE THE DETECTOR SCHEDULE FOR RECORD OF DETECTOR PROGRAMMING INTO THE TRAFFIC SIGNAL CONTROLLER.

PROPOSED PHASING SEQUENCE

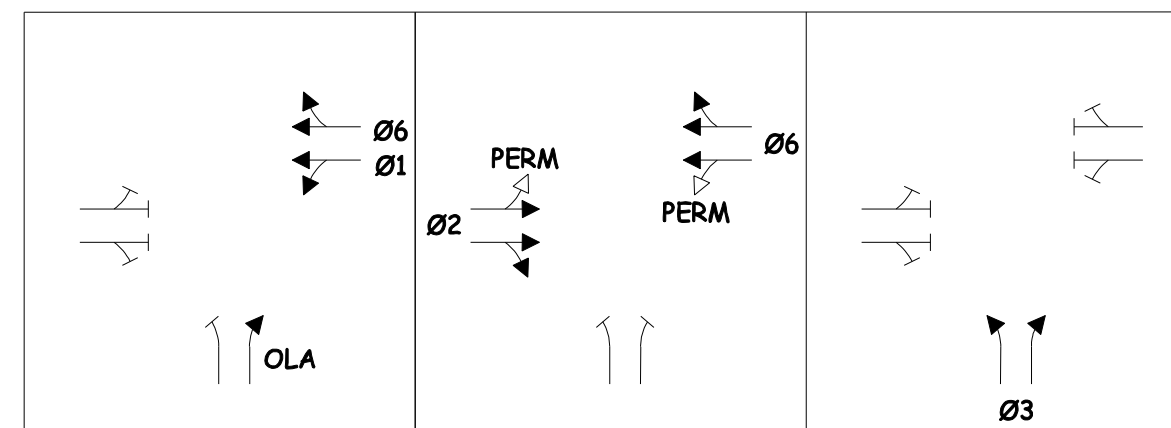

SIGNAL HEAD DATA

PROPOSED		
B1	C2	A1,A2,B2,C1
12" LED LENS	12" LED LENS	12" LED LENS
WITH 5" RETROREFLECTIVE LOUVERED BACKPLATES		

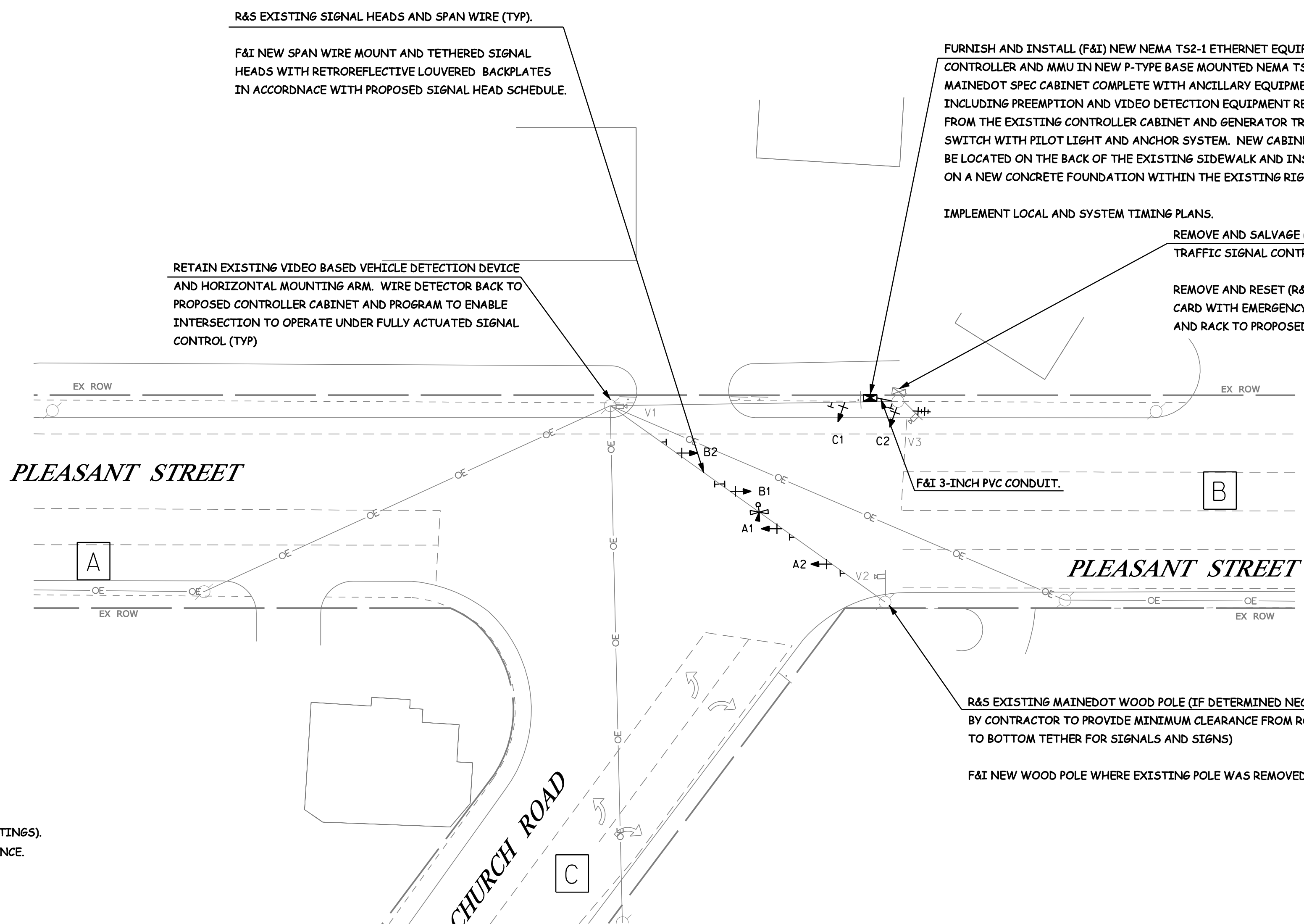

SIGNAL TIMING SCHEDULE

ITEM / PHASE	1	2	3	4	5	6	7	8
MINIMUM INITIAL	5	10	5			10		
PASSAGE TIME	2	3	3			3		
MAXIMUM 1	10	45	30			45		
MAXIMUM 2	15	60	25			60		
YELLOW	3.5	3.5	3.0			3.5		
ALL RED	3.0	3.0	2.5			3.0		
PEDESTRIAN WALK								
PEDESTRIAN CLEARANCE								
RECALL	O	S	O			S		
DETECTOR OPERATION	PR	PR	PR			PR		
PREEMPTION PRIORITY	1	2	3			1		
FLASH	R	Y	R			Y		
DUAL ENTRY	OFF	ON	OFF			ON		

NOTES: S = SOFT RECALL Y = YELLOW
 O = RECALL OFF R = RED
 PR = PRESENCE D = DARK
 MAX2 = UNDER COORDINATION

DAILY & WEEKLY COORDINATION PROGRAM

	MON-FRI	SAT-SUN
FREE OPERATIONS	0000 - 0730 0900 - 1100 1730 - 2400	0000 - 1100 1730 - 2400
PLAN 1 75 SECS MORNING PEAK	0730 - 0900	-
PLAN 2 80 SECS MIDDAY/EVENING PEAK	1100 - 1730	1600 - 1730
PLAN 3 90 SECS SATURDAY PEAK	-	1100 - 1600

SYSTEM DESIGN VOLUMES AM [MID] (PM)

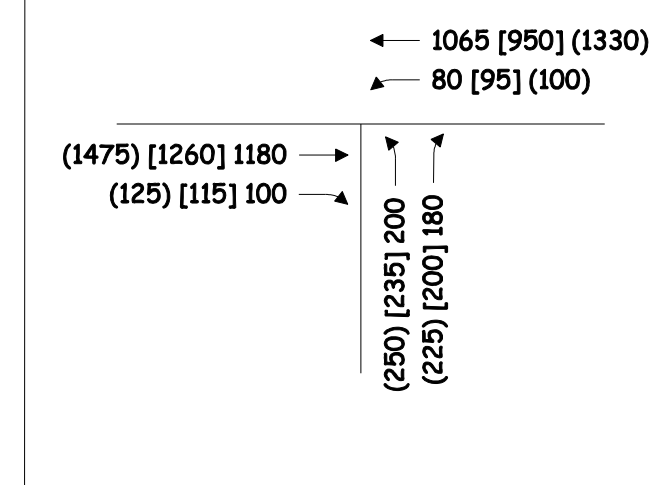

INTERSECTION:
 PLEASANT STREET / CHURCH ROAD
 SIGNAL GROUP:
 1
 LOCATION / PROPOSED DROP:
 1

INTERSECTION BASE PLAN WAS DIGITIZED BY VHB FROM AERIAL PHOTOGRAPHY. SUPPLEMENTAL INFORMATION WAS OBTAINED BY VHB THROUGH FIELD REVIEWS AND INVENTORY CONDUCTED BY MAINE TRAFFIC RESOURCES AS A SUBCONSULTANT TO VHB ON NOVEMBER 6, 2011 AND WITH FOLLOW-UP BY VHB ON NOVEMBER 18, 2011. RIGHT-OF-WAY INFORMATION WAS PROVIDED BY MAINE DOT AS RECORDED IN MAINE FEDERAL AID PROJECT 003138.00 AND TY LIN INTERNATIONAL WITH HUNTER-BALLEW ASSOCIATES INTERSECTION IMPROVEMENT PLANS DATED 1/23/89.

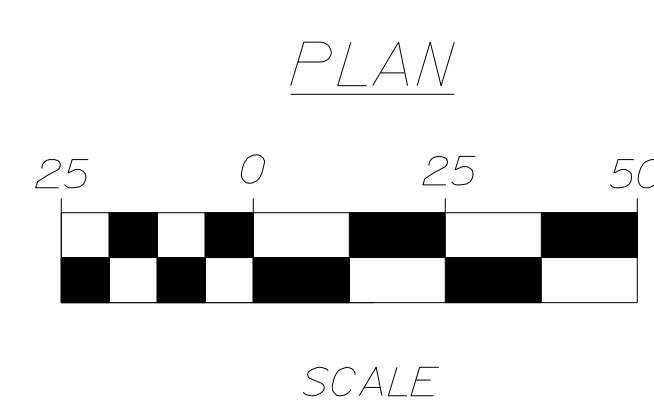

STATE OF MAINE
 DEPARTMENT OF TRANSPORTATION
 AC-STP-1911(900)X
 WIN
 1911900

PROJ. MANAGER	B. KEEZER	DATE
DESIGN-DETAILED	M. GRAHAM	4/16/12
CHECKED-REVIEWED	J. ROBERT	4/24/12
DESIGN-DETAILED	M. GRAHAM	
CHECKED-REVIEWED	C. BOBBY	
DESIGN-DETAILED		
REVISIONS 1		
REVISIONS 2		
REVISIONS 3		
REVISIONS 4		
FIELD CHANGES		

PLEASANT STREET
 CHURCH ROAD
 TRAFFIC SIGNAL PLAN

SHEET NUMBER
 4
 OF 16

Date: 4/26/2012

Username: VHB

Division:

Filename: ... \s\planstet\004_5216700SG01.dgn

LIST OF MAJOR ITEMS

EQUIPMENT AND WORK (ITEM XXX.YYZ)	QUANTITY
FURNISH AND INSTALL (3-INCH) NON-METALLIC CONDUIT (ITEM 626.22)	10 LF
FURNISH AND INSTALL CONTROLLER CABINET FOUNDATION (ITEM 626.35)	1
FURNISH AND INSTALL INTERCONNECT WIRELESS SYSTEM (ITEM 643.90)	1
FURNISH AND INSTALL POLE RISER (INCIDENTAL TO ITEM 643.90)	1
FURNISH AND INSTALL DUAL PURPOSE POLE (ITEM 643.94)	1

THE LISTED QUANTITIES ARE APPROXIMATE AND ARE FURNISHED FOR INFORMATION ONLY.

PROPOSED SPAN WIRE MOUNTED SIGNS

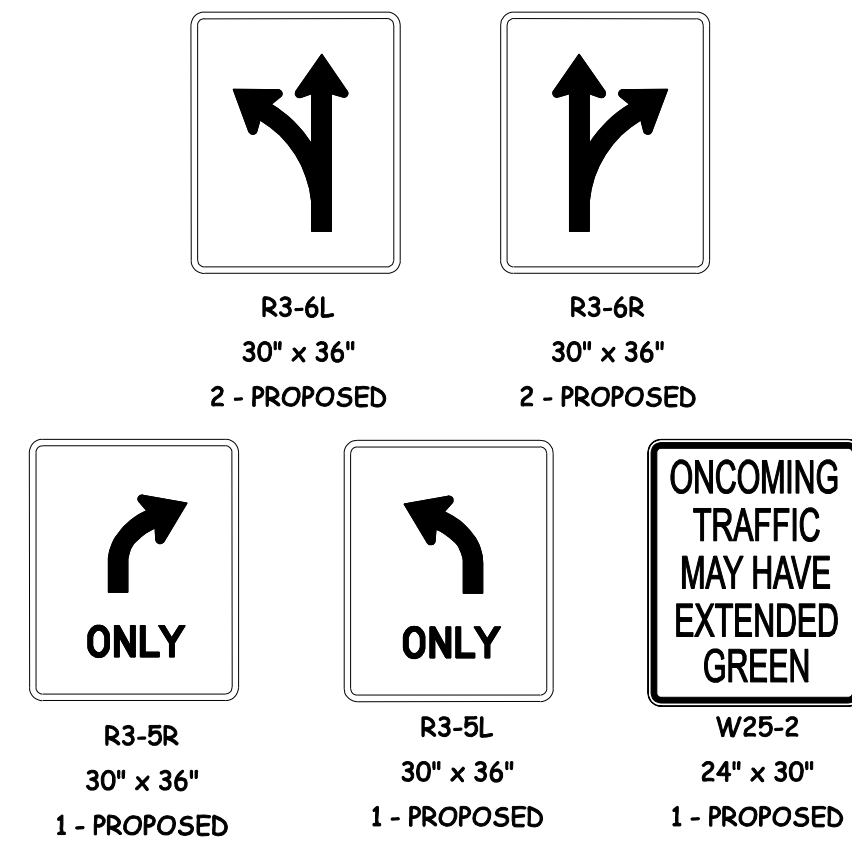

EXISTING POST MOUNTED SIGNS

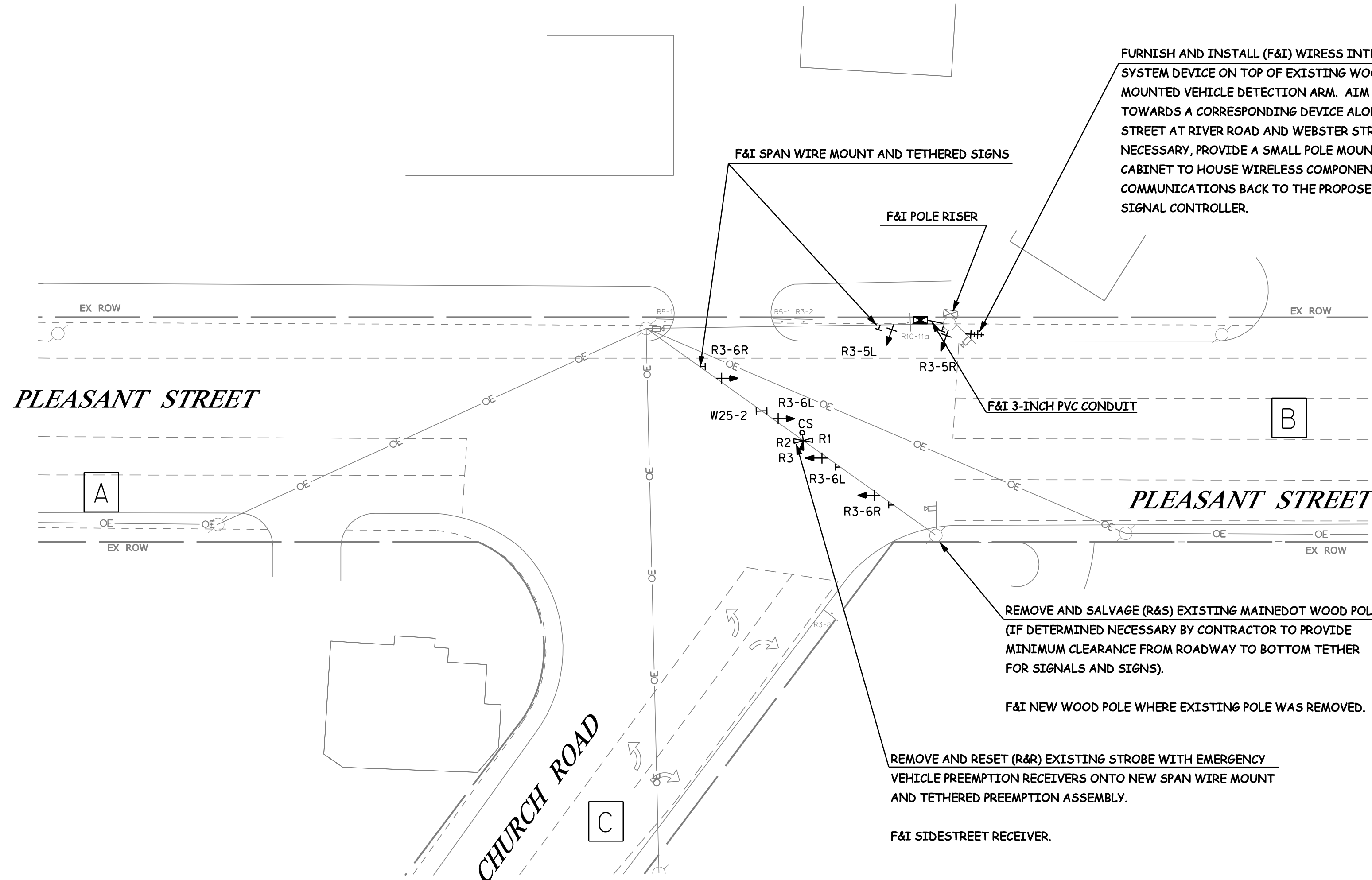
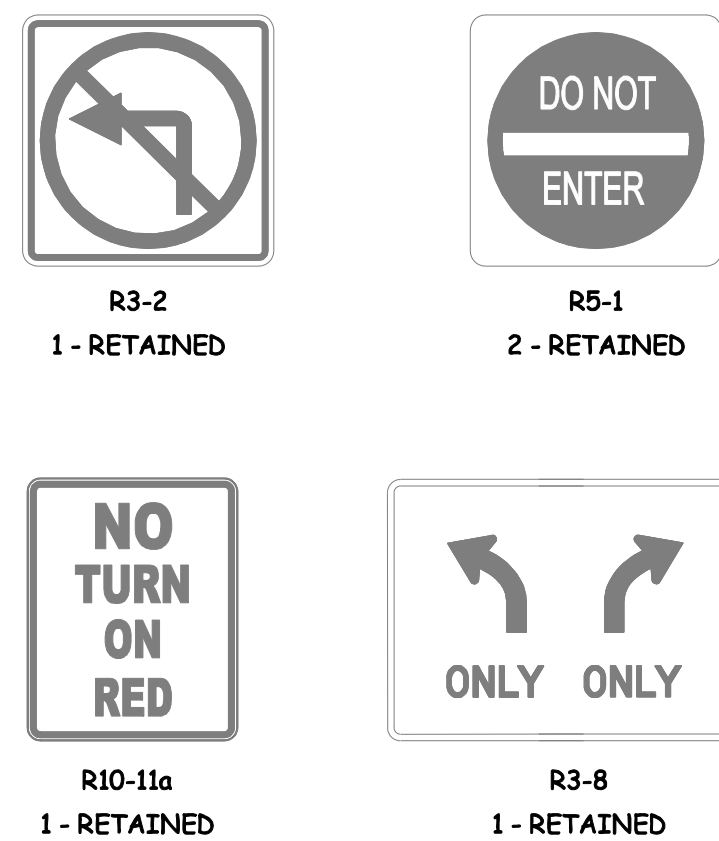

INTERSECTION:
PLEASANT STREET / CHURCH ROAD
SIGNAL GROUP:
1
LOCATION / PROPOSED DROP:
1

INTERSECTION BASE PLAN WAS DIGITIZED BY VHB FROM AERIAL PHOTOGRAPHY. SUPPLEMENTAL INFORMATION WAS OBTAINED BY VHB THROUGH FIELD REVIEWS AND INVENTORY CONDUCTED BY MAINE TRAFFIC RESOURCES AS A SUBCONSULTANT TO VHB ON NOVEMBER 6, 2011 AND WITH FOLLOW-UP BY VHB ON NOVEMBER 18, 2011. RIGHT-OF-WAY INFORMATION WAS PROVIDED BY MAINE DOT AS RECORDED IN MAINE FEDERAL AID PROJECT 003138.00 AND TY LIN INTERNATIONAL WITH HUNTER-BALLEW ASSOCIATES INTERSECTION IMPROVEMENT PLANS DATED 1/23/89.

EMERGENCY VEHICLE PREEMPTION OPERATION

ID	PREEMPT ASSIGNMENT	RECEIVER PRIORITY	ACTIVE PHASE
	1		
	2	NOT USED / RESERVED	
R1	3	1	Ø1 & Ø6
R2	4	2	Ø2
R3	5	3	Ø3

EMERGENCY VEHICLE PREEMPTION NOTES:

- EMERGENCY VEHICLE PREEMPTION SIGNALS SHALL BE TRANSMITTED BY OPTICAL EMITTERS (PROVIDED BY OTHERS) MOUNTED IN EMERGENCY VEHICLES AND RECEIVED BY OPTICAL DETECTORS LOCATED AT THE INTERSECTION.
- PREEMPTION SIGNALS SHALL BE SERVICED ON A PRIORITY BASIS WITH RECEIVERS ASSIGNED DESCENDING PRIORITIES (1 = HIGHEST, 3 = LOWEST)
- IN RESPONSE TO A PREEMPTION SIGNAL RECEIVED AT AN INTERSECTION BY AN OPTICAL DETECTOR, THE CONTROLLER SHALL HOLD OR ADVANCE TO AND HOLD THE EMERGENCY ACTIVE PHASE GREEN FOR A MINIMUM OF 10 SECONDS OR UNTIL THE PREEMPTION SIGNAL CEASES. THE CONTROLLER SHALL THEN TIME PREEMPTION PHASE CLEARANCE (4.0 SECONDS YELLOW AND 2.5 SECONDS ALL RED) AND SERVICE SUBSEQUENT EMERGENCY ACTIVE PHASES AS NECESSARY. AT THE COMPLETION OF THE PREEMPTION CYCLE, THE CONTROLLER SHALL TIME THE PREEMPTION CLEARANCE AND RESUME NORMAL SIGNAL OPERATION.
- MINIMUM GREEN AND NORMAL VEHICLE CLEARANCE SHALL BE PROVIDED ON PHASES THAT ARE TO BE TERMINATED BY PREEMPTION DEMAND.
- EMERGENCY VEHICLE PREEMPTION SHALL OVERRIDE COORDINATION.
- CONFIRMATION STROBES SHALL BE ILLUMINATED WHENEVER ANY EMERGENCY VEHICLE PREEMPTION GREEN IS ON.

PREEMPTION ASSEMBLY DETAIL

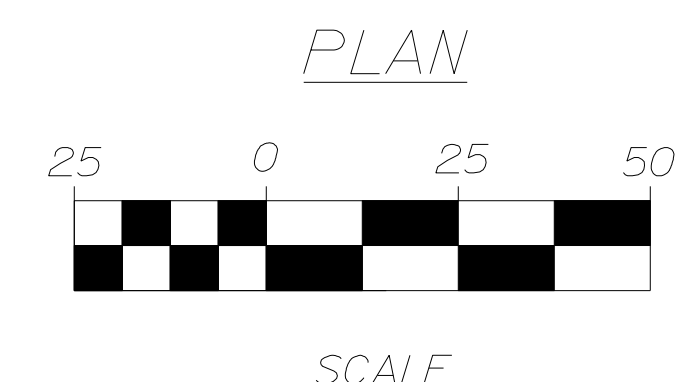
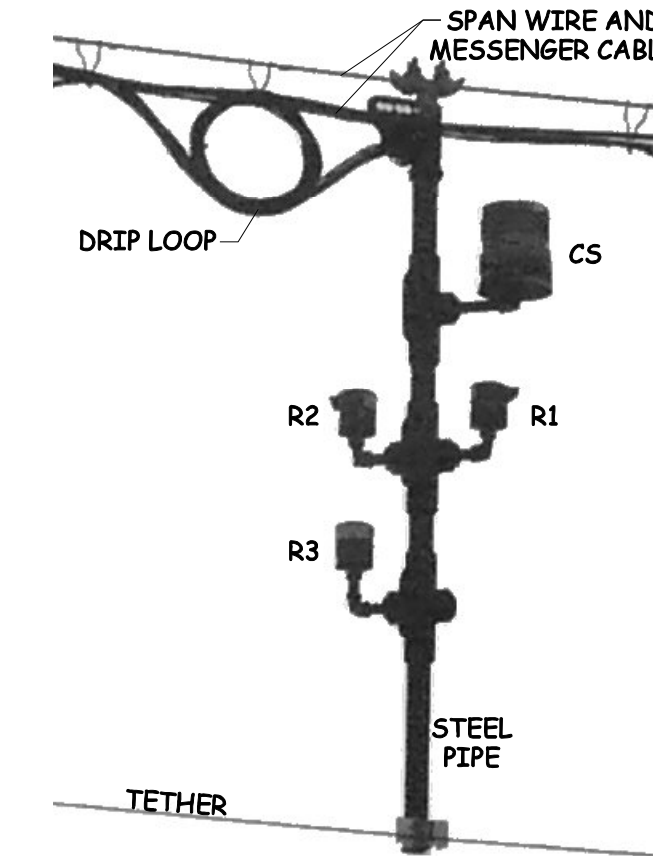

STATE OF MAINE
DEPARTMENT OF TRANSPORTATION
AC-STP-1911(900)X
WIN
1911900

SIGNATURE
P.E. NUMBER
DATE

PROJ. MANAGER	BY	DATE
B. KEIZER	M. GRAHAM	4/16/12
DESIGN-DETAILED	C. BOBBAY	4/24/12
CHECKED-REVIEWED		
DESIGN-2-DETAILED		
DESIGN-3-DETAILED		
REVISIONS 1		
REVISIONS 2		
REVISIONS 3		
REVISIONS 4		
FIELD CHANGES		

PLEASANT STREET
CHURCH ROAD
TRAFFIC SIGNAL PLAN

SHEET NUMBER
5
OF 16

Date: 4/26/2012

Username: VHB

Division:

Filename: ... \planset\005_5216700SG01A.dgn

LIST OF MAJOR ITEMS

EQUIPMENT AND WORK ITEMS 643.71	QUANTITY	EQUIPMENT AND WORK ITEMS 643.71	QUANTITY
FURNISH AND INSTALL NEW NEMA TS2, TYPE 1 ETHERNET EQUIPPED CONTROLLER IN NEW P-TYPE BASE MOUNTED NEMA TS2, TYPE 1 MAINEDOT SPEC CABINET COMPLETE WITH ALL ANCILLARY EQUIPMENT AND WIRING INCLUDING PREEMPTION AND VIDEO DETECTION EQUIPMENT RESET FROM THE EXISTING CONTROLLER CABINET.	1	FURNISH AND INSTALL EMERGENCY VEHICLE PREEMPTION DETECTOR AND DETECTOR CABLE	1
16-CHANNEL ETHERNET EQUIPPED ENHANCED MALFUNCTION MANAGEMENT UNIT	1	FURNISH AND INSTALL SPAN WIRE MOUNT AND TETHER PREEMPTION ASSEMBLY	1
FURNISH AND INSTALL ONE-WAY, 3-SECTION, 12-INCH SPAN WIRE MOUNTED TRAFFIC SIGNAL HEADS WITH RETROREFLECTIVE LOUVERED BACKPLATES	8	FURNISH AND INSTALL OVERHEAD MOUNTED SIGN	12
FURNISH AND INSTALL ONE-WAY, 5-SECTION "DOGHOUSE" 12-INCH SPAN WIRE MOUNTED TRAFFIC SIGNAL HEAD WITH RETROREFLECTIVE LOUVERED BACKPLATES	1	FURNISH AND INSTALL SPAN WIRE AND TETHER WIRE	150 LF
BRACKET MOUNTED 16 x 18 INCH COUNTDOWN PEDESTRIAN SIGNAL HEAD PAINTED BLACK. INDICATION SHALL BE ENERGY EFFICIENT, 6ELCORE 6T1 LED OR APPROVED EQUAL	6	FURNISH AND INSTALL NEW SIGNAL CABLE	-
ADA COMPLIANT ACCESSIBLE PEDESTRIAN SIGNAL (APS) PUSH BUTTON WITH R10-3e INFORMATIONAL SIGN	6	IMPLEMENT LOCAL AND SYSTEM TIMING	-
FURNISH AND INSTALL ENVIRONMENTALLY HARDENED ETHERNET SWITCH	1	THE LISTED QUANTITIES ARE APPROXIMATE AND ARE FURNISHED FOR INFORMATION ONLY.	
FURNISH AND INSTALL GENERATOR TRANSFER SWITCH WITH PILOT LIGHT AND ANCHOR SYSTEM	1	FURNISH AND INSTALL (F&I) NEW NEMA TS2-1 ETHERNET EQUIPPED CONTROLLER AND MMU IN NEW P-TYPE BASE MOUNTED NEMA TS2-1 MAINEDOT SPEC CABINET COMPLETE WITH ANCILLARY EQUIPMENT INCLUDING PREEMPTION AND VIDEO DETECTION EQUIPMENT RESET FROM THE EXISTING CONTROLLER CABINET AND GENERATOR TRANSFER SWITCH WITH PILOT LIGHT AND ANCHOR SYSTEM. NEW CABINET IS TO BE LOCATED ON THE BACK OF THE EXISTING SIDEWALK AND INSTALLED ON A NEW CONCRETE FOUNDATION WITHIN THE EXISTING RIGHT-OF-WAY.	
		IMPLEMENT LOCAL AND SYSTEM TIMING PLANS.	

PROPOSED PHASING SEQUENCE

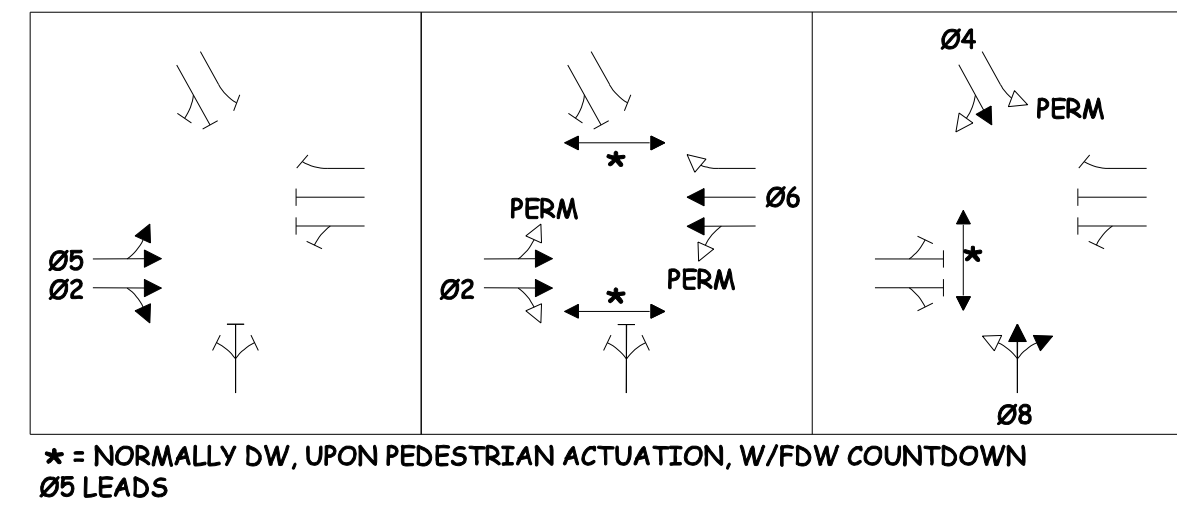

SIGNAL HEAD DATA

PROPOSED		
A1	A2,B1,B2,B3,C1,C2,D1,D2	P1 - P6
12" LED LENS	12" LED LENS	16" x 18" LED PEDESTRIAN SIGNAL
WITH 5" RETROREFLECTIVE LOUVERED BACKPLATES		

STATE OF MAINE
DEPARTMENT OF TRANSPORTATION
AC-STP-1911(900)X
WIN
1911900

PROJ. MANAGER	BY	DATE	SIGNATURE	P.E. NUMBER	DATE
M. GRAHAM	M. GRAHAM	4/16/12			
J. ROBERT	C. BOBBAY	4/24/12			
DESIGN-DETAILED	DESIGN-REVIEWED	DESIGN-DETAILED2	REVISIONS 1	REVISIONS 2	REVISIONS 3
			REVISIONS 4	FIELD CHANGES	

SIGNAL TIMING SCHEDULE

ITEM / PHASE	1	2	3	4	5	6	7	8
MINIMUM INITIAL		10		5	5	10		5
PASSAGE TIME		3		2	2	3		2
MAXIMUM 1		45		35	15	45		35
MAXIMUM 2		60		35	15	60		35
YELLOW		3.5		3.5	3.5	3.5		3.5
ALL RED		3.5		3.5	3.5	3.5		3.5
PEDESTRIAN WALK		7		7		7		7
PEDESTRIAN CLEARANCE		22		13		22		
RECALL		S		O	O	S		O
DETECTOR OPERATION		PR		PR	PR	PR		PR
PREEMPTION PRIORITY		2		3	2	1		4
FLASH		Y		R	R	Y		R
DUAL ENTRY		ON		ON	OFF	ON		ON

NOTES: S = SOFT RECALL
O = RECALL OFF
PR = PRESENCE
MAX2 = UNDER COORDINATION
Y = YELLOW
R = RED
D = DARK

DAILY & WEEKLY COORDINATION PROGRAM

	MON-FRI	SAT-SUN
FREE OPERATIONS	0000 - 0730 0900 - 1100 1730 - 2400	0000 - 1100 1730 - 2400
PLAN 1 75 SECS MORNING PEAK	0730 - 0900	-
PLAN 2 80 SECS MIDDAY/EVENING PEAK	1100 - 1730	1600 - 1730
PLAN 3 90 SECS SATURDAY PEAK	-	1100 - 1600

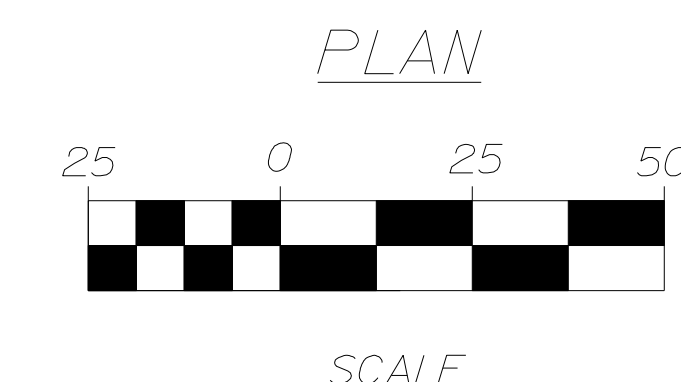

PLEASANT STREET
RIVER ROAD
TRAFFIC SIGNAL PLAN

SHEET NUMBER
6
OF 16

COORDINATION CYCLE/SPLIT/OFFSET SCHEDULE

ALL ENTRIES IN SECONDS

	PLAN 1	PLAN 2	PLAN 3
CYCLE LENGTH	75	80	90
OFFSET (END GRN)	48	52	68
COORDINATED Ø	2	2	2
SPLIT TIME Ø1	0	0	0
SPLIT TIME Ø2	47	52	62
SPLIT TIME Ø3	0	0	0
SPLIT TIME Ø4	28	28	28
SPLIT TIME Ø5	13	15	13
SPLIT TIME Ø6	34	37	49
SPLIT TIME Ø7	0	0	0
SPLIT TIME Ø8	28	28	28

COORDINATION MODE SET TO FIXED FORCE-OFF

COORDINATION NOTES:

- OFFSET IS REFERENCED TO THE END OF THE COORDINATED PHASE.
- COORDINATION TO OPERATE BY TIME-OF-DAY (SEE SHEET 2 FOR DAY PLAN SETTINGS).
- TRAFFIC SIGNAL CONTROLLER SHALL BE SET FOR STOP TIME IN WALK TO ON.

DETECTOR SCHEDULE

	DETECTOR				DETECTOR CARD IN VEHICLE DETECTION RACK				
	PLAN ID	STREET	DIRECTION	LANE	Ø	TYPE	SLOT NO	DETECTOR NO	CHANNEL
CAMERA V1									
CAMERA V2									
CAMERA V3									
CAMERA V4									

DETECTOR NOTES:

CONTRACTOR SHALL COMPLETE THE DETECTOR SCHEDULE FOR RECORD OF DETECTOR PROGRAMMING INTO THE TRAFFIC SIGNAL CONTROLLER.

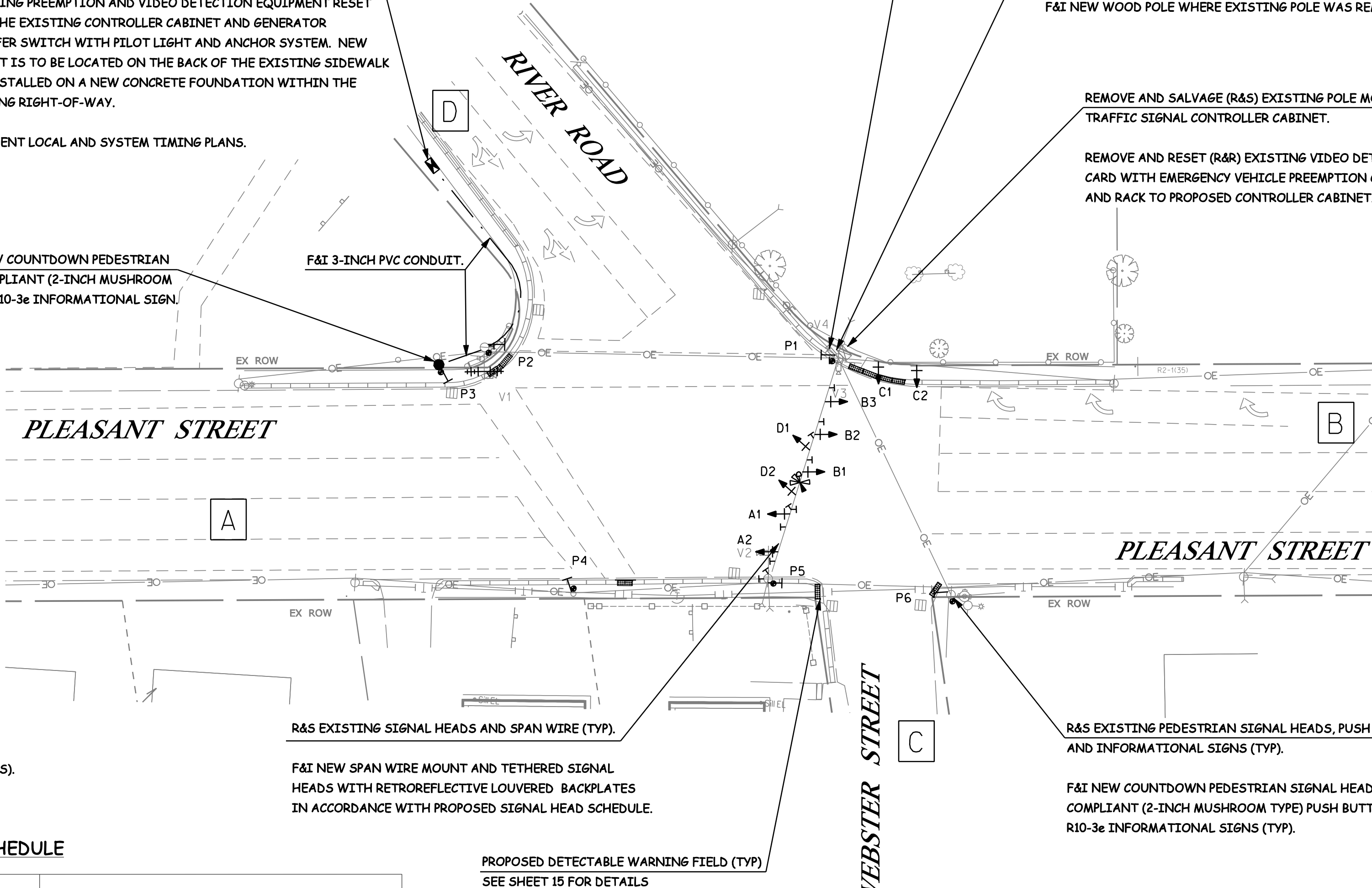

INTERSECTION:
PLEASANT STREET / RIVER ROAD
SIGNAL GROUP:
1
LOCATION / PROPOSED DROP:
2

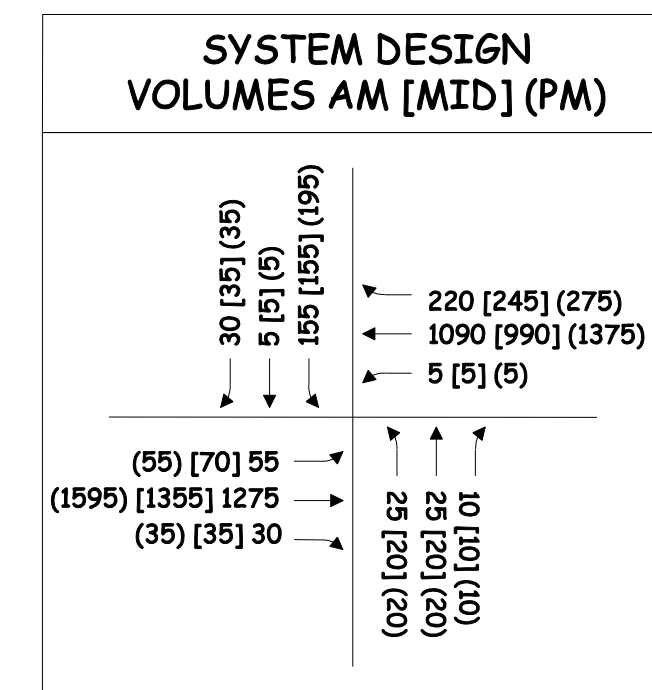

INTERSECTION BASE PLAN AND RIGHT-OF-WAY WAS PROVIDED BY MAINEDOT SURVEY WITH ADDITIONAL REFERENCE TO TY LIN INTERNATIONAL WITH HUNTER-BALLEW ASSOCIATES INTERSECTION IMPROVEMENT PLAN DATED 3/1/89. SUPPLEMENTAL INFORMATION WAS OBTAINED BY VHB THROUGH FIELD REVIEWS AND INVENTORY CONDUCTED BY MAINE TRAFFIC RESOURCES AS A SUBCONSULTANT TO VHB ON NOVEMBER 6, 2011 AND WITH FOLLOW-UP BY VHB ON NOVEMBER 18, 2011.

LIST OF MAJOR ITEMS

EQUIPMENT AND WORK (ITEM XXX.YYZ)	QUANTITY
FURNISH AND INSTALL (3-INCH) NON-METALLIC CONDUIT (ITEM 626.22)	77 LF
FURNISH AND INSTALL 18-INCH FOUNDATION (ITEM 626.31)	1
FURNISH AND INSTALL CONTROLLER CABINET FOUNDATION (ITEM 626.35)	1
FURNISH AND INSTALL INTERCONNECT WIRELESS SYSTEM (ITEM 643.90)	1
FURNISH AND INSTALL POLE RISER (INCIDENTAL TO ITEM 643.90)	1
FURNISH AND INSTALL 8-FOOT PEDESTAL POLE (ITEM 643.92)	1
FURNISH AND INSTALL DUAL PURPOSE POLE (ITEM 643.94)	1

THE LISTED QUANTITIES ARE APPROXIMATE AND ARE FURNISHED FOR INFORMATION ONLY.

PROPOSED SPAN WIRE AND BRACKET MOUNTED SIGNS

R3-6L
 30" x 36"
 2 - PROPOSED

R3-6R
 30" x 36"
 2 - PROPOSED

R3-5L
 30" x 36"
 1 - PROPOSED

R3-5R
 30" x 36"
 1 - PROPOSED

R3-5a
 30" x 36"
 1 - PROPOSED

W25-2
 30" x 36"
 1 - PROPOSED

R10-15L
 30" x 30"
 1 - PROPOSED

R10-15R
 30" x 30"
 3 - PROPOSED

R10-3eL
 9" x 15" *
 3 - PROPOSED

R10-3eR
 9" x 15" *
 3 - PROPOSED

* INCORPORATED INTO APS ASSEMBLY

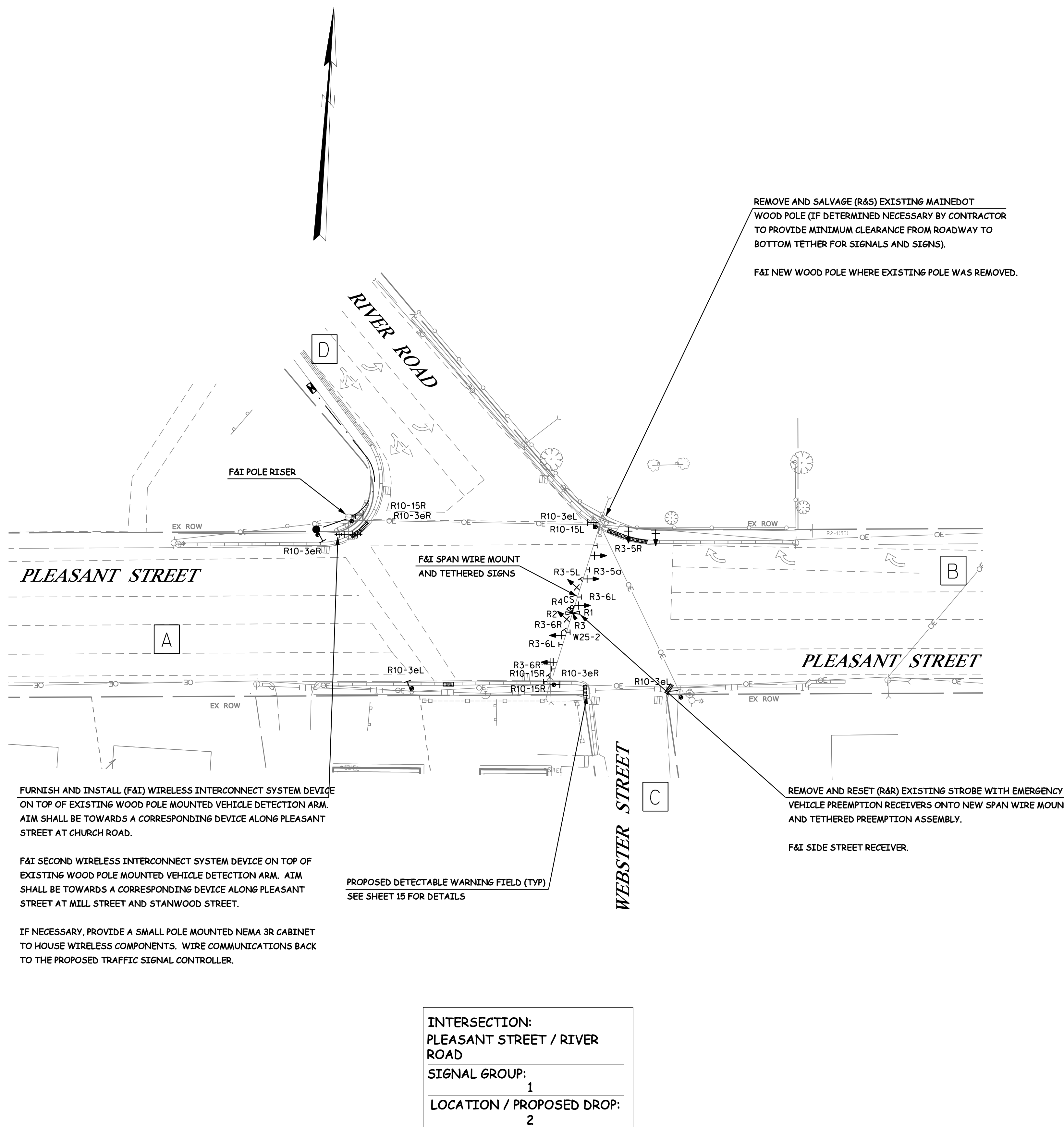

EMERGENCY VEHICLE PREEMPTION OPERATION

ID	PREEMPT ASSIGNMENT	RECEIVER PRIORITY	ACTIVE PHASE
	1	NOT USED / RESERVED	
	2		
R1	3	1	Ø6
R2	4	2	Ø2 & Ø5
R3	5	3	Ø4
R4	6	4	Ø8

EMERGENCY VEHICLE PREEMPTION NOTES:

- EMERGENCY VEHICLE PREEMPTION SIGNALS SHALL BE TRANSMITTED BY OPTICAL EMITTERS (PROVIDED BY OTHERS) MOUNTED IN EMERGENCY VEHICLES AND RECEIVED BY OPTICAL DETECTORS LOCATED AT THE INTERSECTION.
- PREEMPTION SIGNALS SHALL BE SERVICED ON A PRIORITY BASIS WITH RECEIVERS ASSIGNED DESCENDING PRIORITIES (1 = HIGHEST, 4 = LOWEST)
- IN RESPONSE TO A PREEMPTION SIGNAL RECEIVED AT AN INTERSECTION BY AN OPTICAL DETECTOR, THE CONTROLLER SHALL HOLD OR ADVANCE TO AND HOLD THE EMERGENCY ACTIVE PHASE GREEN FOR A MINIMUM OF 10 SECONDS OR UNTIL THE PREEMPTION SIGNAL CEASES. THE CONTROLLER SHALL THEN TIME PREEMPTION PHASE CLEARANCE (4.0 SECONDS YELLOW AND 3.5 SECONDS ALL RED) AND SERVICE SUBSEQUENT EMERGENCY ACTIVE PHASES AS NECESSARY. AT THE COMPLETION OF THE PREEMPTION CYCLE, THE CONTROLLER SHALL TIME THE PREEMPTION CLEARANCE AND RESUME NORMAL SIGNAL OPERATION.
- MINIMUM GREEN AND NORMAL VEHICLE CLEARANCE SHALL BE PROVIDED ON PHASES THAT ARE TO BE TERMINATED BY PREEMPTION DEMAND.
- EMERGENCY VEHICLE PREEMPTION SHALL OVERRIDE COORDINATION.
- CONFIRMATION STROBES SHALL BE ILLUMINATED WHENEVER ANY EMERGENCY VEHICLE PREEMPTION GREEN IS ON.

PREEMPTION ASSEMBLY DETAIL

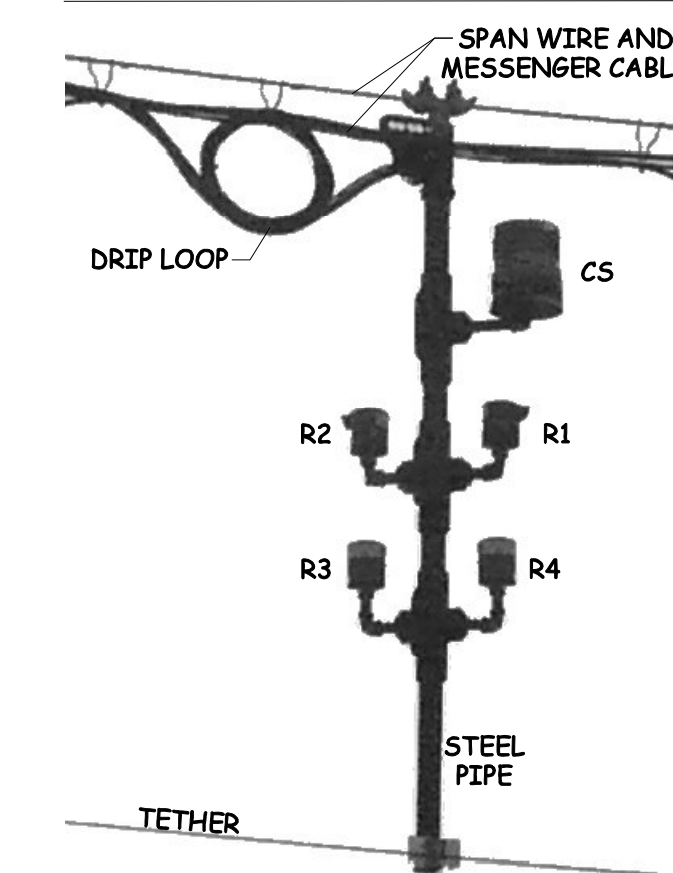

PLAN

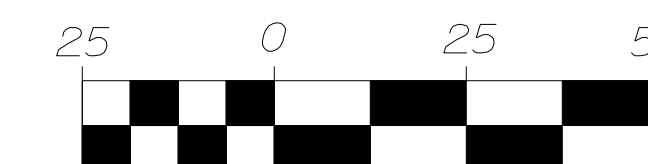

SCALE

STATE OF MAINE
DEPARTMENT OF TRANSPORTATION
AC-STP-1911(900)X
WIN
1911900

PROJ. MANAGER	B. KEEZER	DATE
DESIGN-DETAILED	M. GRAHAM	4/16/12
CHECKED-REVIEWED	J. ROBERT	4/24/12
DESIGN-2-DETAILED		
DESIGN-3-DETAILED		
REVISIONS 1		
REVISIONS 2		
REVISIONS 3		
REVISIONS 4		
FIELD CHANGES		

PLEASANT STREET
RIVER ROAD
TRAFFIC SIGNAL PLAN

SHEET NUMBER

7

OF 16

INTERSECTION BASE PLAN AND RIGHT-OF-WAY WAS PROVIDED BY MAINEDOT SURVEY WITH ADDITIONAL REFERENCE TO TY LIN INTERNATIONAL WITH HUNTER-BALLEW ASSOCIATES INTERSECTION IMPROVEMENT PLAN DATED 3/1/89. SUPPLEMENTAL INFORMATION WAS OBTAINED BY VHB THROUGH FIELD REVIEWS AND INVENTORY CONDUCTED BY MAINE TRAFFIC RESOURCES AS A SUBCONSULTANT TO VHB ON NOVEMBER 6, 2011 AND WITH FOLLOW-UP BY VHB ON NOVEMBER 18, 2011.

LIST OF MAJOR ITEMS

EQUIPMENT AND WORK ITEMS 643.71	QUANTITY
FURNISH AND INSTALL NEW NEMA TS2, TYPE 1 ETHERNET EQUIPPED MASTER AND LOCAL IN NEW P-TYPE BASE MOUNTED NEMA TS2, TYPE 1 MAINEDOT SPEC CABINET COMPLETE WITH ALL ANCILLARY EQUIPMENT AND WIRING INCLUDING PREEMPTION AND VIDEO DETECTION EQUIPMENT RESET FROM THE EXISTING CONTROLLER CABINET.	1
16-CHANNEL ETHERNET EQUIPPED ENHANCED MALFUNCTION MANAGEMENT UNIT	1
FURNISH AND INSTALL ONE-WAY, 3-SECTION, 12-INCH ASTROBRACKET MOUNTED TRAFFIC SIGNAL HEAD WITH RETROREFLECTIVE LOUVERED BACKPLATE	7
BRACKET MOUNTED 16 x 18 INCH COUNTDOWN PEDESTRIAN SIGNAL HEAD PAINTED BLACK. INDICATION SHALL BE ENERGY EFFICIENT, 6ELCORE 6TL LED OR APPROVED EQUAL	2
ADA COMPLIANT ACCESSIBLE PEDESTRIAN SIGNAL (APS) PUSH BUTTON WITH R10-3e INFORMATIONAL SIGN	2
REMOVE AND RESET EXISTING MAST ARM POLE ONTO NEW FOUNDATION	1
FURNISH AND INSTALL ENVIRONMENTALLY HARDENED ETHERNET SWITCH	1
FURNISH AND INSTALL GENERATOR TRANSFER SWITCH WITH PILOT LIGHT AND ANCHOR SYSTEM	1
FURNISH AND INSTALL OVERHEAD MOUNTED SIGNS	4
FURNISH AND INSTALL NEW SIGNAL CABLE	-
IMPLEMENT LOCAL AND SYSTEM TIMING	-

THE LISTED QUANTITIES ARE APPROXIMATE AND ARE FURNISHED FOR INFORMATION ONLY.

INSERT A

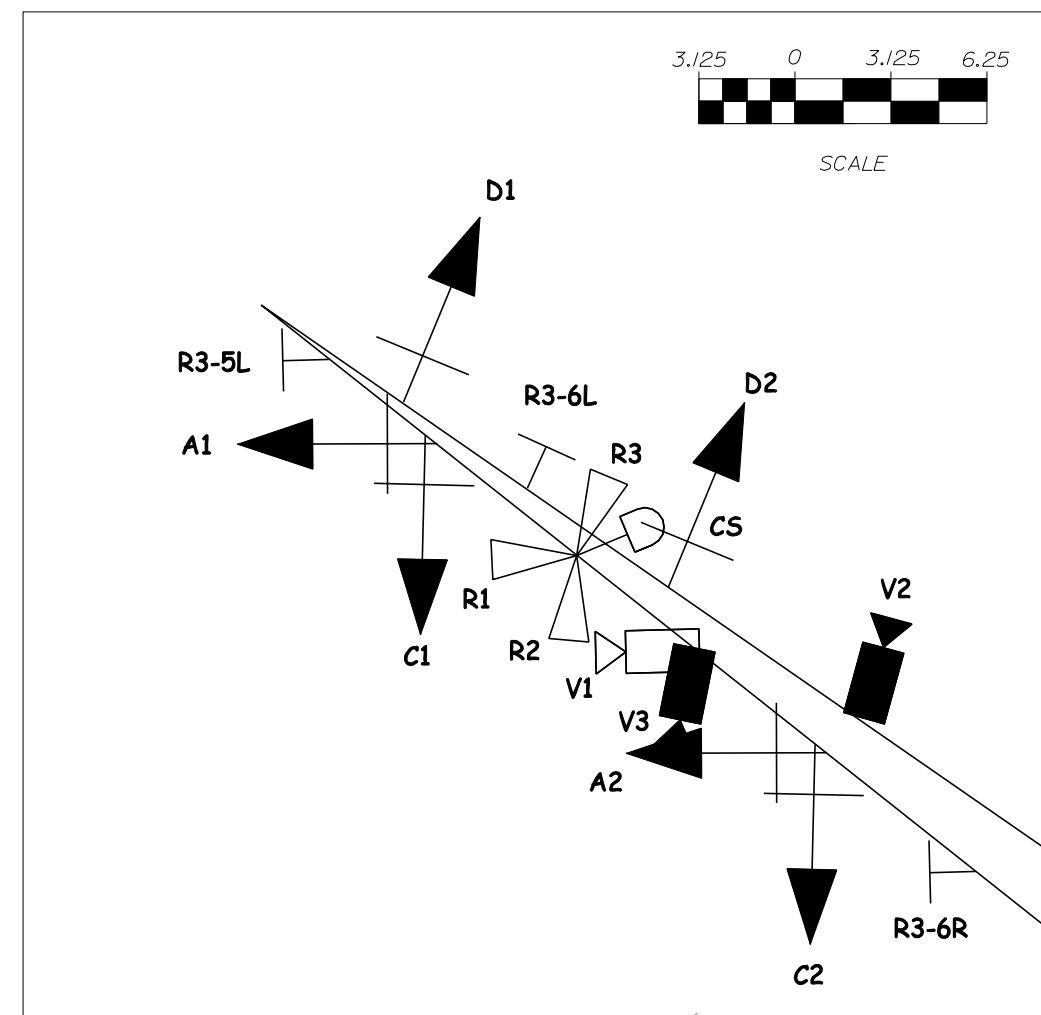

PROPOSED PHASING SEQUENCE

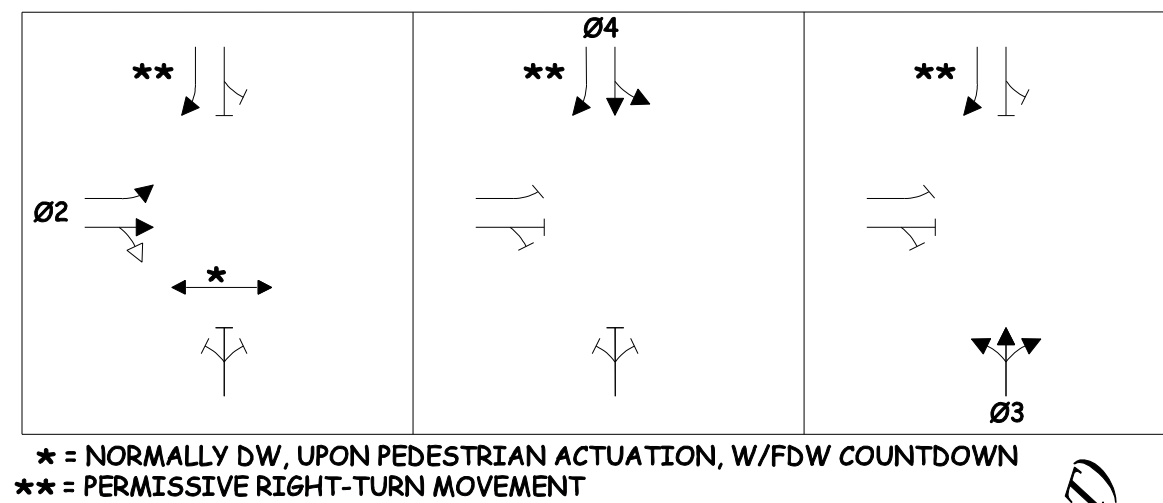

** = NORMALLY DW, UPON PEDESTRIAN ACTUATION, W/PDW COUNTDOWN
 *** = PERMISSIVE RIGHT-TURN MOVEMENT

SIGNAL HEAD DATA

PROPOSED		
C1	A1,A2,C2,C3,D1,D2	P1 - P2
12" LED LENS	12" LED LENS	16" x 18" LED PEDESTRIAN SIGNAL
WITH 5" RETROREFLECTIVE LOUVERED BACKPLATES		

RETAIN EXISTING VIDEO BASED VEHICLE DETECTION DEVICE (V1). FURNISH AND INSTALL NEW VIDEO BASED VEHICLE DETECTION DEVICES (V2 & V3). WIRE DETECTORS BACK TO PROPOSED CONTROLLER CABINET AND PROGRAM TO ENABLE INTERSECTION TO OPERATE UNDER FULLY ACTUATED SIGNAL CONTROL.

FURNISH AND INSTALL (F&I) NEW NEMA TS2-1 ETHERNET EQUIPPED CONTROLLER AND MMU IN NEW P-TYPE BASE MOUNTED NEMA TS2-1 MAINEDOT SPEC CABINET COMPLETE WITH ANCILLARY EQUIPMENT INCLUDING PREEMPTION AND VIDEO DETECTION EQUIPMENT RESET FROM THE EXISTING CONTROLLER CABINET AND GENERATOR TRANSFER SWITCH WITH PILOT LIGHT AND ANCHOR SYSTEM. NEW CABINET IS TO BE LOCATED ON THE BACK OF THE EXISTING SIDEWALK AND INSTALLED ON A NEW CONCRETE FOUNDATION WITHIN THE EXISTING RIGHT-OF-WAY.

IMPLEMENT LOCAL AND SYSTEM TIMING PLANS.

SIGNAL TIMING SCHEDULE

ITEM / PHASE	1	2	3	4	5	6	7	8
MINIMUM INITIAL	10	5	5					
PASSAGE TIME	3	3	3					
MAXIMUM 1	100	60	40					
MAXIMUM 2	95	60	40					
YELLOW	3.5	3.5	3.5					
ALL RED	2.5	2.5	2.5					
PEDESTRIAN WALK	7							
PEDESTRIAN CLEARANCE	10							
RECALL	S	O	O					
DETECTOR OPERATION	PR	PR	PR					
PREEMPTION PRIORITY	1	2	3					
FLASH	Y	R	R					
DUAL ENTRY	OFF	OFF	OFF					

NOTES: S = SOFT RECALL
 O = RECALL OFF
 PR = PRESENCE
 MAX2 = UNDER COORDINATION
 Y = YELLOW
 R = RED
 D = DARK

COORDINATION CYCLE/SPLIT/OFFSET SCHEDULE

ALL ENTRIES IN SECONDS

CYCLE LENGTH	COORDINATION MODE SET TO FIXED FORCE-OFF		
	PLAN 1	PLAN 2	PLAN 3
OFFSET (END GRN)	0	0	0
COORDINATED Ø	2	2	2
SPLIT TIME Ø1	0	0	0
SPLIT TIME Ø2	80	83	94
SPLIT TIME Ø3	45	51	55
SPLIT TIME Ø4	25	26	31
SPLIT TIME Ø6	0	0	0
SPLIT TIME Ø7	0	0	0
SPLIT TIME Ø8	0	0	0

COORDINATION NOTES:

- OFFSET IS REFERENCED TO THE END OF THE COORDINATED PHASE.
- COORDINATION TO OPERATE BY TIME-OF-DAY (SEE SHEET 2 FOR DAY PLAN SETTINGS).
- TRAFFIC SIGNAL CONTROLLER SHALL BE SET FOR STOP TIME IN WALK TO ON.
- PHASES 7 AND 8 ARE DUMMY PHASES TO BE SET WITH SPLIT TIMES FOR NTCP COMPLIANCE.

DETECTOR SCHEDULE

DETECTOR	DETECTOR				DETECTOR CARD IN VEHICLE DETECTION RACK				
	PLAN ID	STREET	DIRECTION	LANE	Ø	TYPE	SLOT NO	DETECTOR NO	CHANNEL
CAMERA V1	1								
	2								
	3								
	4								
CAMERA V2	5	MILL STREET	SOUTHBOUND	LEFT/THROUGH	4	FULL VIDEO	4	2/1	1
	6	SPARE							
	7	SPARE							
CAMERA V3	8	SPARE							
	9	STANWOOD ST	NORTHBOUND	LEFT	3	FULL VIDEO	6	3/1	1
	10	STANWOOD ST	NORTHBOUND	THROUGH/RIGHT	3	FULL VIDEO	6	3/2	2
	11	SPARE							
	12	SPARE							

DETECTOR NOTES:

CONTRACTOR SHALL COMPLETE THE DETECTOR SCHEDULE FOR RECORD OF DETECTOR PROGRAMMING INTO THE TRAFFIC SIGNAL CONTROLLER.

INTERSECTION:
 PLEASANT STREET / MILL STREET / STANWOOD STREET
 SIGNAL GROUP:
 1
 LOCATION / PROPOSED DROP:
 3

SYSTEM DESIGN VOLUMES AM [MID] (PM)

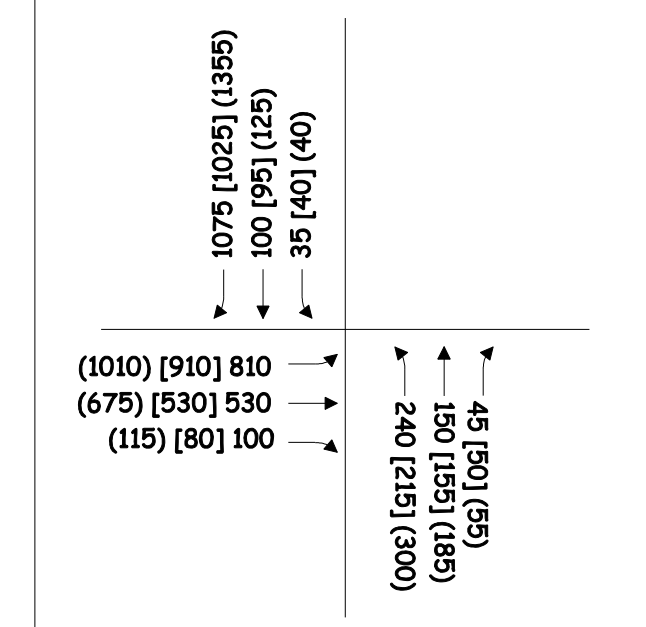

DAILY & WEEKLY COORDINATION PROGRAM

	MON-FRI	SAT-SUN
FREE OPERATIONS	0000 - 0730 0900 - 1100 1730 - 2400	0000 - 1100 1730 - 2400
PLAN 1 75 SECS MORNING PEAK	0730 - 0900	-
PLAN 2 80 SECS MIDDAY/EVENING PEAK	1100 - 1730	1600 - 1730
PLAN 3 90 SECS SATURDAY PEAK	-	1100 - 1600

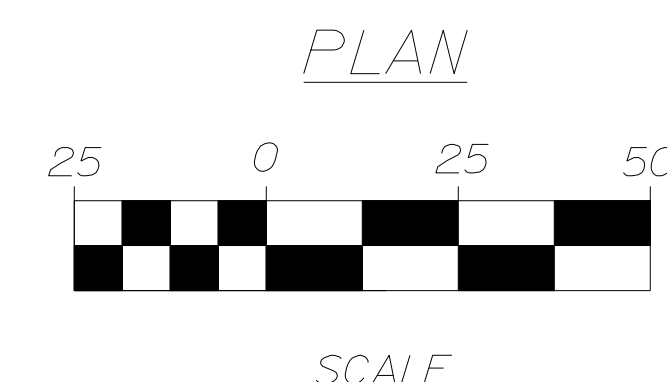

STATE OF MAINE
 DEPARTMENT OF TRANSPORTATION
 AC-STP-1911(900)X
 WIN
 1911900

PROJ. MANAGER	B. KEEZER	DATE
DESIGN-DETAILED	M. GRAHAM	4/16/12
CHECKED-REVIEWED	J. ROBERT	4/24/12
DESIGN-DETAILED	M. GRAHAM	
DESIGN-DETAILED	C. BOBBY	
REVISIONS 1		
REVISIONS 2		
REVISIONS 3		
REVISIONS 4		
FIELD CHANGES		

PLEASANT STREET
 MILL STREET / STANWOOD STREET
 TRAFFIC SIGNAL PLAN

SHEET NUMBER

8

OF 16

Date: 4/26/2012

Username: VHB

Division:

Filename: ... \s\planset\009_5216700SC03.dgn

INTERSECTION BASE PLAN WAS DIGITIZED BY VHB FROM AERIAL PHOTOGRAPHY. SUPPLEMENTAL INFORMATION WAS OBTAINED BY VHB THROUGH FIELD REVIEWS AND INVENTORY CONDUCTED BY MAINE TRAFFIC RESOURCES AS A SUBCONSULTANT TO VHB ON NOVEMBER 4, 2011 AND WITH FOLLOW-UP BY VHB ON NOVEMBER 18, 2011. RIGHT-OF-WAY INFORMATION WAS PROVIDED BY TOWN OF BRUNSWICK SIGNAL AND STRIPING IMPROVEMENT PLAN DATED 5/8/95 AND STETELINES, PA SURVEY WORK SHEET OF LAND DATED 11/4/11.

LIST OF MAJOR ITEMS

EQUIPMENT AND WORK (ITEM XXX.YYZ)	QUANTITY	EQUIPMENT AND WORK (ITEM XXX.YYZ)	QUANTITY
FURNISH AND INSTALL RUMBLE STRIP (ITEM 202.205)	100 LF	FURNISH AND INSTALL 12" SOLID WHITE MARKING LINE (ITEM 627.18)	100 LF
FURNISH AND INSTALL PRECAST CONCRETE JUNCTION BOX (ITEM 626.11)	1	FURNISH AND INSTALL VIDEO DETECTION CAMERA (ITEM 643.83)	2
FURNISH AND INSTALL (3-INCH) NON-METALLIC CONDUIT (ITEM 626.22)	102 LF	FURNISH AND INSTALL INTERCONNECT WIRELESS SYSTEM (ITEM 643.90)	1
FURNISH AND INSTALL 18-INCH FOUNDATION (ITEM 626.31)	1	FURNISH AND INSTALL 8-FOOT PEDESTAL POST (ITEM 643.92)	1
FURNISH AND INSTALL 36-INCH FOUNDATION FOR MAST ARM POLE (ITEM 626.331)	1	THE LISTED QUANTITIES ARE APPROXIMATE AND ARE FURNISHED FOR INFORMATION ONLY.	
FURNISH AND INSTALL CONTROLLER CABINET FOUNDATION (ITEM 626.35)	1		
REMOVE EXISTING CONCRETE MAST ARM FOUNDATION (ITEM 626.36)	1		

BID ALTERNATE 1 LIST OF MAJOR EQUIPMENT

EQUIPMENT AND WORK (ITEM XXX.YYZ)	QUANTITY
FURNISH AND INSTALL TRAFFIC CONTROL SYSTEM (ITEM 643.81)	1
FURNISH AND INSTALL ENVIRONMENTALLY HARDENED FIBER SWITCH (INCIDENTAL TO ITEM 643.81)	2
FURNISH AND INSTALL DUAL USE SPLICE ENCLOSURE AND 12-POSITION PATCH PANEL (INCIDENTAL TO ITEM 643.81)	2
PROVIDE TRAFFIC CONTROL SYSTEM TRAINING (INCIDENTAL TO ITEM 643.81)	18 HRS
FURNISH AND INSTALL VIDEO DETECTION MEDIA CONVERTERS IN LOCATIONS 1, 2, 3, AND 5 CONTROL CABINETS (INCIDENTAL TO ITEM 643.81)	4
FURNISH AND INSTALL APPROXIMATELY 1000 LINEAR FEET OF 12-STRAND FIBER OPTIC INTERCONNECT CABLE (ITEM 643.90)	1

THE LISTED QUANTITIES ARE APPROXIMATE AND ARE FURNISHED FOR INFORMATION ONLY.

EMERGENCY VEHICLE PREEMPTION OPERATION

ID	PREEMPT ASSIGNMENT	RECEIVER PRIORITY	ACTIVE PHASE
	1		
	2	NOT USED / RESERVED	
R1	3	1	Ø2
R2	4	2	Ø3
R3	5	3	Ø4

EMERGENCY VEHICLE PREEMPTION NOTES:

- EMERGENCY VEHICLE PREEMPTION SIGNALS SHALL BE TRANSMITTED BY OPTICAL EMITTERS (PROVIDED BY OTHERS) MOUNTED IN EMERGENCY VEHICLES AND RECEIVED BY OPTICAL DETECTORS LOCATED AT THE INTERSECTION.
- PREEMPTION SIGNALS SHALL BE SERVICED ON A PRIORITY BASIS WITH RECEIVERS ASSIGNED DESCENDING PRIORITIES (1 = HIGHEST, 3 = LOWEST)
- IN RESPONSE TO A PREEMPTION SIGNAL RECEIVED AT AN INTERSECTION BY AN OPTICAL DETECTOR, THE CONTROLLER SHALL HOLD OR ADVANCE TO AND HOLD THE EMERGENCY ACTIVE PHASE GREEN FOR A MINIMUM OF 10 SECONDS OR UNTIL THE PREEMPTION SIGNAL CEASES. THE CONTROLLER SHALL THEN TIME PREEMPTION PHASE CLEARANCE (4.0 SECONDS YELLOW AND 2.5 SECONDS ALL RED) AND SERVICE SUBSEQUENT EMERGENCY ACTIVE PHASES AS NECESSARY. AT THE COMPLETION OF THE PREEMPTION CYCLE, THE CONTROLLER SHALL TIME THE PREEMPTION CLEARANCE AND RESUME NORMAL SIGNAL OPERATION.
- MINIMUM GREEN AND NORMAL VEHICLE CLEARANCE SHALL BE PROVIDED ON PHASES THAT ARE TO BE TERMINATED BY PREEMPTION DEMAND.
- EMERGENCY VEHICLE PREEMPTION SHALL OVERRIDE COORDINATION.
- CONFIRMATION STROBES SHALL BE ILLUMINATED WHENEVER ANY EMERGENCY VEHICLE PREEMPTION GREEN IS ON.

PROPOSED MAST ARM AND BRACKET MOUNTED SIGNS

R3-6L
30" x 36"
1 - PROPOSED

R3-6R
30" x 36"
1 - PROPOSED

R3-5L
30" x 36"
1 - PROPOSED

R10-3eL
9" x 15" *
1 - PROPOSED

R10-3eR
9" x 15" *
1 - PROPOSED

R10-15R
30" x 30"
1 - PROPOSED

* INCORPORATED INTO APS ASSEMBLY

EXISTING POST MOUNTED SIGNS

R6-1L
1 - RETAINED

R4-7
4 - RETAINED

OMI-1
4 - RETAINED

R3-2
1 - RETAINED

W12-1
1 - RETAINED

R6-1R
1 - RETAINED

D9-2
2 - RETAINED

R10-6
1 - RETAINED

R3-4
1 - RETAINED

R5-1a
1 - RETAINED

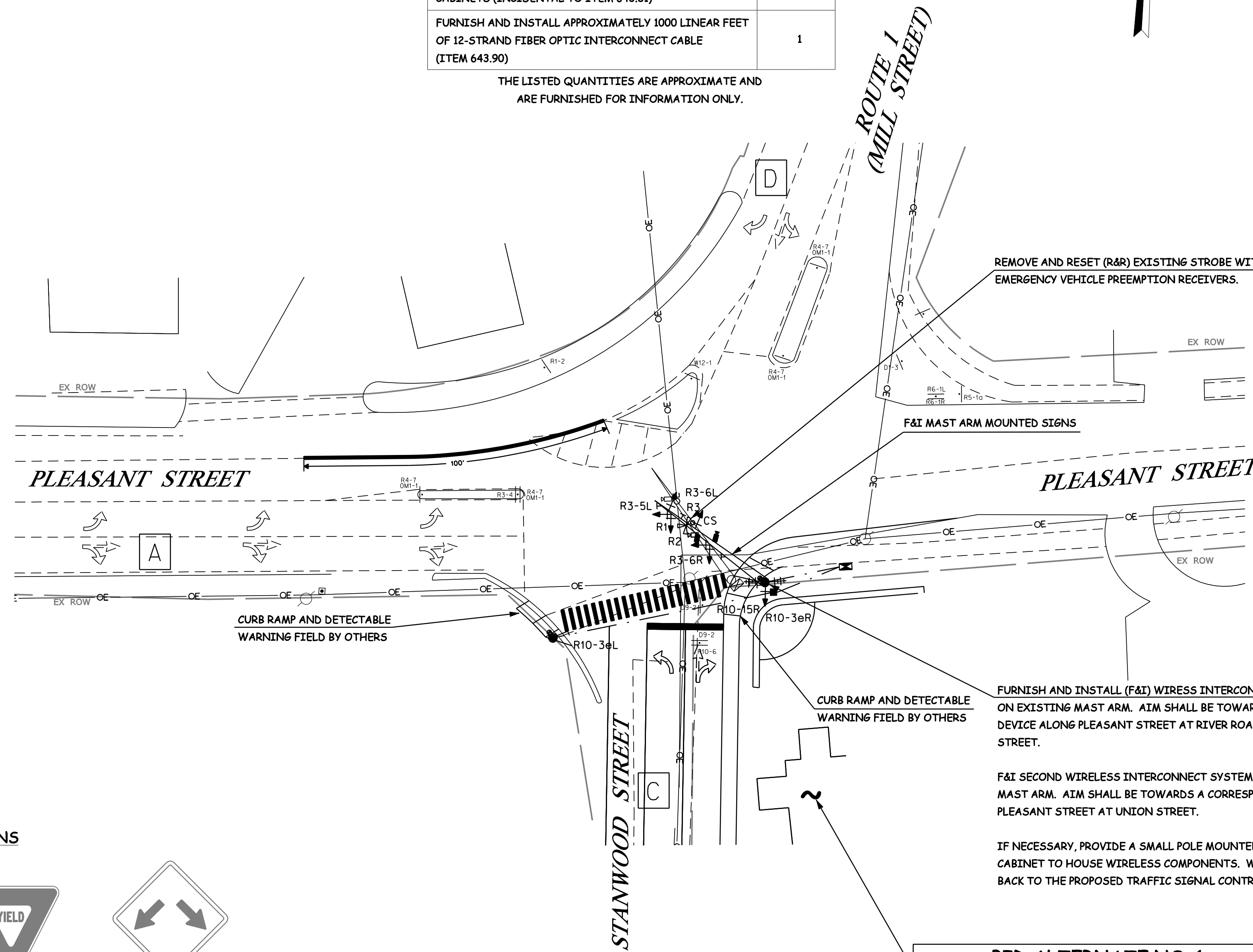

INTERSECTION:
PLEASANT STREET / MILL STREET / STANWOOD STREET
SIGNAL GROUP:
1
LOCATION / PROPOSED DROP:
3

BID ALTERNATE NO. 1

PROPOSED TRAFFIC CONTROL SYSTEM SERVER INSTALLED IN (FUTURE) BRUNSWICK POLICE DEPARTMENT BUILD. SERVER SHALL BE CONNECTED TO ETHERNET SWITCH THAT SHALL CONNECT TO A SIMILAR SWITCH TO BE INSTALLED IN THE PROPOSED LOCATION 3 CONTROLLER CABINET. SWITCHES SHALL BE CONNECTED BY PROPOSED 12-STRAND SINGLE MODE FIBER OPTIC CABLE TO BE RUN BETWEEN CONTROLLER CABINET AND BUILDING WITHIN MUNICIPAL SPACE ON EXISTING UTILITY POLES. FIBER OPTIC CONNECTION MAY OPTIONALLY BE PROVIDED THROUGH UNDERGROUND CONDUIT INSTALLED BY THE TOWN.

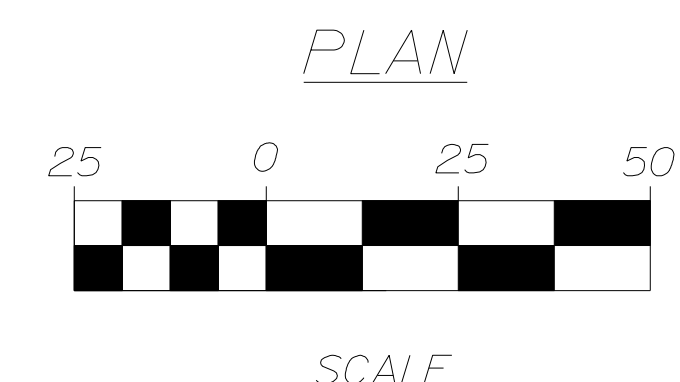

Date: 5/29/2012

Username: VHB

Division:

Filename: ... \plan\set\010_5216700503A.dgn

STATE OF MAINE
DEPARTMENT OF TRANSPORTATION
AC-STP-1911(900)X
WIN
1911900

PROJ. MANAGER	B. KEEZER	BY	DATE
DESIGN-DETAILED	M. GRAHAM	M. GRAHAM	4/16/12
CHECKED-REVIEWED	J. ROBERT	C. BOBBAY	4/24/12
DESIGN-2-DETAILED			
DESIGN-3-DETAILED			
REVISIONS 1			
REVISIONS 2			
REVISIONS 3			
REVISIONS 4			
FIELD CHANGES			

PLEASANT STREET
MILL STREET / STANWOOD STREET
TRAFFIC SIGNAL PLAN

SHEET NUMBER
9
OF 16

LIST OF MAJOR ITEMS

EQUIPMENT AND WORK ITEMS 643.71	QUANTITY	EQUIPMENT AND WORK ITEMS 643.71	QUANTITY
FURNISH AND INSTALL NEW NEMA TS2, TYPE 1 ETHERNET EQUIPPED CONTROLLER IN NEW P-TYPE BASE MOUNTED NEMA TS2, TYPE 1 MAINEDOT SPEC CABINET COMPLETE WITH ALL ANCILLARY EQUIPMENT AND WIRING INCLUDING PREEMPTION AND VIDEO DETECTION EQUIPMENT.	1	FURNISH AND INSTALL PREEMPTION CONFIRMATION RED STROBE WITH CABLE ON A SPAN WIRE PIPE ASSEMBLY	1
		FURNISH AND INSTALL 4-CHANNEL PREEMPTION PHASE SELECTOR WITH SYSTEM CHASSIS	1
16-CHANNEL ETHERNET EQUIPPED ENHANCED MALFUNCTION MANAGEMENT UNIT	1	FURNISH AND INSTALL OVERHEAD MOUNTED SIGN	6
FURNISH AND INSTALL ONE-WAY, 3-SECTION, 12-INCH SPAN WIRE MOUNTED TRAFFIC SIGNAL HEAD WITH RETROREFLECTIVE LOUVERED BACKPLATES	6	FURNISH AND INSTALL SPAN WIRE AND TETHER WIRE	150 LF
		FURNISH AND INSTALL NEW SIGNAL CABLE	-
		IMPLEMENT LOCAL AND SYSTEM TIMING	-
BRACKET MOUNTED 16 x 18 INCH COUNTDOWN PEDESTRIAN SIGNAL HEAD PAINTED BLACK. INDICATION SHALL BE ENERGY EFFICIENT, 6ELCORE 6TI LED OR APPROVED EQUAL	8		
ADA COMPLIANT ACCESSIBLE PEDESTRIAN SIGNAL (APS) PUSH BUTTON WITH R10-3e INFORMATIONAL SIGN	4		
FURNISH AND INSTALL ENVIRONMENTALLY HARDENED ETHERNET SWITCH	1		
FURNISH AND INSTALL GENERATOR TRANSFER SWITCH WITH PILOT LIGHT AND ANCHOR SYSTEM	1		
FURNISH AND INSTALL EMERGENCY VEHICLE PREEMPTION DETECTOR AND DETECTOR CABLE	3		

THE LISTED QUANTITIES ARE APPROXIMATE AND ARE FURNISHED FOR INFORMATION ONLY.

FURNISH AND INSTALL (F&I) NEW NEMA TS2-1 ETHERNET EQUIPPED CONTROLLER AND MMU IN NEW P-TYPE BASE MOUNTED NEMA TS2-1 MAINEDOT SPEC CABINET COMPLETE WITH ANCILLARY EQUIPMENT INCLUDING NEW PREEMPTION AND VIDEO DETECTION EQUIPMENT AND GENERATOR TRANSFER SWITCH WITH PILOT LIGHT AND ANCHOR SYSTEM. NEW CABINET IS TO BE LOCATED ON THE FACE OF THE EXISTING SIDEWALK AND INSTALLED ON A NEW CONCRETE FOUNDATION WITHIN THE EXISTING RIGHT-OF-WAY.

IMPLEMENT LOCAL AND SYSTEM TIMING PLANS.

PROPOSED PHASING SEQUENCE

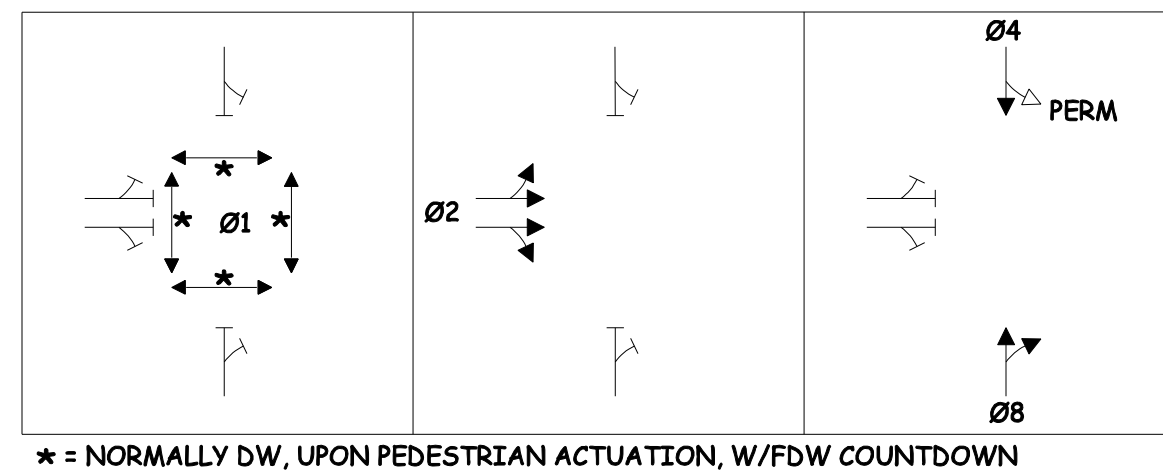

SIGNAL HEAD DATA

PROPOSED	
A1,A2,C1,C2,D1,D2	P1 - P8
12" LED LENS WITH 5" RETROREFLECTIVE LOUVERED BACKPLATES	16" x 18" LED PEDESTRIAN SIGNAL

SIGNAL TIMING SCHEDULE

ITEM / PHASE	1	2	3	4	5	6	7	8
MINIMUM INITIAL		7		5				5
PASSAGE TIME		3		2				2
MAXIMUM 1		35		20				20
MAXIMUM 2		60		45				45
YELLOW	3.0	3.0		3.0				3.0
ALL RED	0	2.5		2.5				2.5
PEDESTRIAN WALK	7							
PEDESTRIAN CLEARANCE	9							
RECALL		S		O				O
DETECTOR OPERATION		PR		PR				PR
PREEMPTION PRIORITY		1		2				3
FLASH	D	Y		R				R
DUAL ENTRY		OFF		ON				ON

NOTES: S = SOFT RECALL
O = RECALL OFF
PR = PRESENCE
MAX2 = UNDER COORDINATION
Y = YELLOW
R = RED
D = DARK

COORDINATION CYCLE/SPLIT/OFFSET SCHEDULE

ALL ENTRIES IN SECONDS

	PLAN 1	PLAN 2	PLAN 3
CYCLE LENGTH	75	80	90
OFFSET (END GRN)	50	52	28
COORDINATED Ø	2	2	2
SPLIT TIME Ø1	20	20	20
SPLIT TIME Ø2	26	28	33
SPLIT TIME Ø3	0	0	0
SPLIT TIME Ø4	29	32	37
SPLIT TIME Ø5	0	0	0
SPLIT TIME Ø6	0	0	0
SPLIT TIME Ø7	0	0	0
SPLIT TIME Ø8	29	32	37

COORDINATION NOTES:

- OFFSET IS REFERENCED TO THE END OF THE COORDINATED PHASE.
- COORDINATION TO OPERATE BY TIME-OF-DAY (SEE SHEET 2 FOR DAY PLAN SETTINGS).
- TRAFFIC SIGNAL CONTROLLER SHALL BE SET FOR STOP TIME IN WALK TO ON.

DETECTOR SCHEDULE

	DETECTOR				DETECTOR CARD IN VEHICLE DETECTION RACK				
	PLAN ID	STREET	DIRECTION	LANE	Ø	TYPE	SLOT NO	DETECTOR NO	CHANNEL
CAMERA V1	1	PLEASANT ST	EASTBOUND	LEFT-THROUGH	2	FULL VIDEO	2	1/1	1
	2	PLEASANT ST	EASTBOUND	THROUGH-RIGHT	2	FULL VIDEO	2	1/2	2
	3	SPARE							
	4	SPARE							
CAMERA V2	5	UNION ST	NORTHBOUND	THROUGH-RIGHT	8	FULL VIDEO	4	2/1	1
	6	SPARE							
	7	SPARE							
CAMERA V3	8	SPARE							
	9	UNION ST	SOUTHBOUND	LEFT-THROUGH	4	FULL VIDEO	6	3/1	1
	10	SPARE							
	11	SPARE							
	12	SPARE							

INTERSECTION:
PLEASANT STREET / UNION STREET
SIGNAL GROUP:
1
LOCATION / PROPOSED DROP:
4

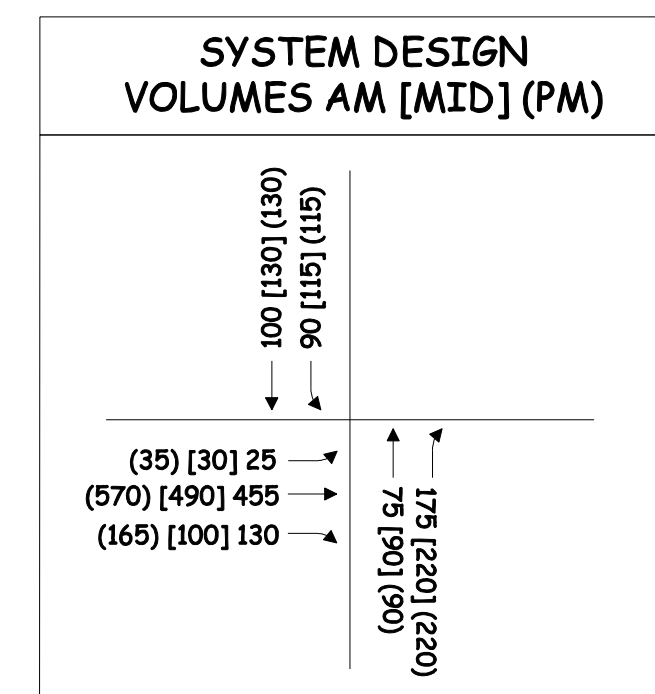

DAILY & WEEKLY COORDINATION PROGRAM

	MON-FRI	SAT-SUN
FREE OPERATIONS	0000 - 0730 0900 - 1100 1730 - 2400	0000 - 1100 1730 - 2400
PLAN 1 75 SECS MORNING PEAK	0730 - 0900	-
PLAN 2 80 SECS MIDDAY/EVENING PEAK	1100 - 1730	1600 - 1730
PLAN 3 90 SECS SATURDAY PEAK	-	1100 - 1600

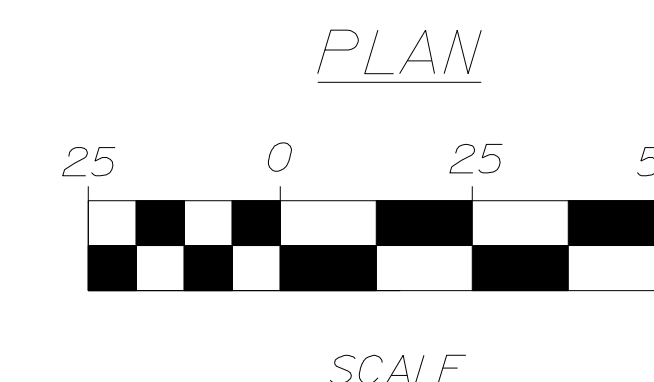

INTERSECTION BASE PLAN AND RIGHT-OF-WAY WAS PROVIDED BY MAINEDOT SURVEY. SUPPLEMENTAL INFORMATION WAS OBTAINED BY VHB THROUGH FIELD REVIEWS AND INVENTORY CONDUCTED BY MAINE TRAFFIC RESOURCES AS A SUBCONSULTANT TO VHB ON NOVEMBER 4, 2011 AND WITH FOLLOW-UP BY VHB ON NOVEMBER 18, 2011.

STATE OF MAINE
DEPARTMENT OF TRANSPORTATION
AC-STP-1911(900)X
WIN
1911900

PROJ. MANAGER	B. KEEZER	DATE
DESIGN-DETAILED	M. GRAHAM	4/16/12
CHECKED-REVIEWED	J. ROBERT	4/24/12
DESIGN-DETAILED	C. BOBBAY	
DESIGN-DETAILED		
REVISIONS 1		
REVISIONS 2		
REVISIONS 3		
REVISIONS 4		
FIELD CHANGES		

PLEASANT STREET
UNION STREET
TRAFFIC SIGNAL PLAN

SHEET NUMBER
10
OF 16

Date: 4/26/2012

Username: VHB

Division:

Filename: ... \s\planset\011_5216700SC04.dgn

LIST OF MAJOR ITEMS

EQUIPMENT AND WORK (ITEM XXX.YYZ)	QUANTITY
FURNISH AND INSTALL (3-INCH) NON-METALLIC CONDUIT (ITEM 626.22)	10 LF
FURNISH AND INSTALL CONTROLLER CABINET FOUNDATION (ITEM 626.35)	1
FURNISH AND INSTALL 8-SLOT VIDEO DETECTOR RACK (ITEM 643.83)	1
FURNISH AND INSTALL 4-CHANNEL CARD RACK MOUNT DATA AND PRESENCE VIDEO DETECTOR CARD (ITEM 643.83)	1
FURNISH AND INSTALL CARD RACK VIDEO POWER SUPPLY (ITEM 643.83)	1
FURNISH AND INSTALL VIDEO DETECTION CAMERA (ITEM 643.83)	3
FURNISH AND INSTALL POLE RISER (INCIDENTAL TO ITEM 643.90)	1
FURNISH AND INSTALL INTERCONNECT WIRELESS SYSTEM (ITEM 643.90)	1

THE LISTED QUANTITIES ARE APPROXIMATE AND ARE FURNISHED FOR INFORMATION ONLY.

PROPOSED SPAN WIRE AND BRACKET MOUNTED SIGNS



R10-3e
9' x 15' *
4 - PROPOSED

* INCORPORATED INTO APS ASSEMBLY

EXISTING POST MOUNTED SIGNS



R2-1(25)
1 - RETAINED



D11-1
1 - RETAINED

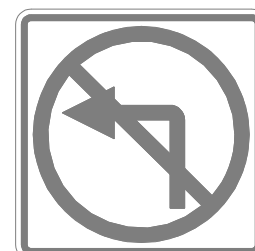

R3-2
2 - RETAINED



R6-1R
2 - RETAINED



R6-1L
2 - RETAINED

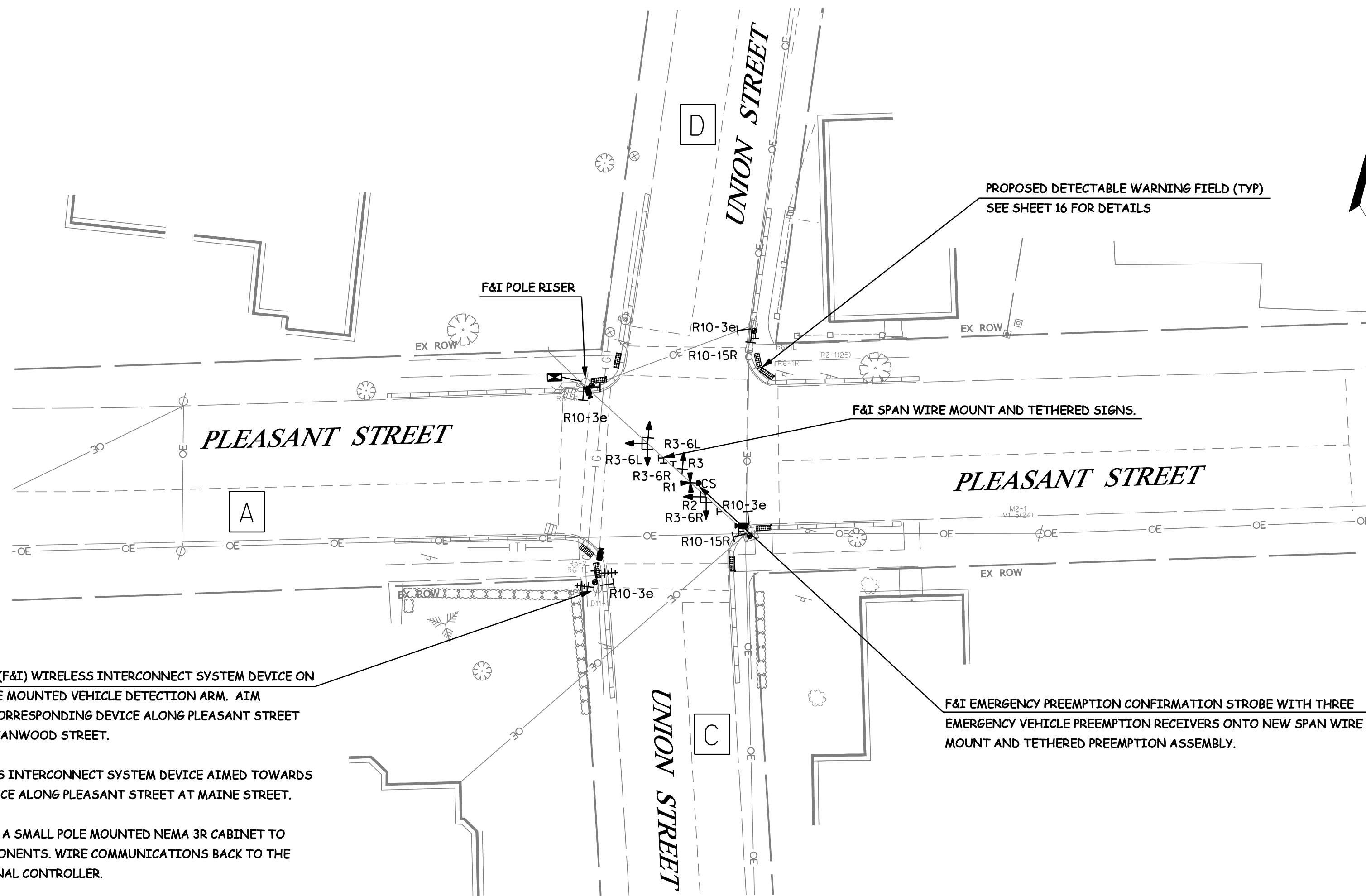

INTERSECTION:
PLEASANT STREET / UNION STREET
SIGNAL GROUP:
1
LOCATION / PROPOSED DROP:
4

INTERSECTION BASE PLAN AND RIGHT-OF-WAY WAS PROVIDED BY MAINE DOT SURVEY. SUPPLEMENTAL INFORMATION WAS OBTAINED BY VHB THROUGH FIELD REVIEWS AND INVENTORY CONDUCTED BY MAINE TRAFFIC RESOURCES AS A SUBCONSULTANT TO VHB ON NOVEMBER 4, 2011 AND WITH FOLLOW-UP BY VHB ON NOVEMBER 18, 2011.

EMERGENCY VEHICLE PREEMPTION OPERATION

ID	PREEMPT ASSIGNMENT	RECEIVER PRIORITY	ACTIVE PHASE
	1		
	2	NOT USED / RESERVED	
R1	3	1	Ø2
R2	4	2	Ø4
R3	5	3	Ø8
	6	NOT USED	

EMERGENCY VEHICLE PREEMPTION NOTES:

- EMERGENCY VEHICLE PREEMPTION SIGNALS SHALL BE TRANSMITTED BY OPTICAL EMITTERS (PROVIDED BY OTHERS) MOUNTED IN EMERGENCY VEHICLES AND RECEIVED BY OPTICAL DETECTORS LOCATED AT THE INTERSECTION.
- PREEMPTION SIGNALS SHALL BE SERVICED ON A PRIORITY BASIS WITH RECEIVERS ASSIGNED DESCENDING PRIORITIES (1 = HIGHEST, 3 = LOWEST)
- IN RESPONSE TO A PREEMPTION SIGNAL RECEIVED AT AN INTERSECTION BY AN OPTICAL DETECTOR, THE CONTROLLER SHALL HOLD OR ADVANCE TO AND HOLD THE EMERGENCY ACTIVE PHASE GREEN FOR A MINIMUM OF 10 SECONDS OR UNTIL THE PREEMPTION SIGNAL CEASES. THE CONTROLLER SHALL THEN TIME PREEMPTION PHASE CLEARANCE (4.0 SECONDS YELLOW AND 2.5 SECONDS ALL RED) AND SERVICE SUBSEQUENT EMERGENCY ACTIVE PHASES AS NECESSARY. AT THE COMPLETION OF THE PREEMPTION CYCLE, THE CONTROLLER SHALL TIME THE PREEMPTION CLEARANCE AND RESUME NORMAL SIGNAL OPERATION.
- MINIMUM GREEN AND NORMAL VEHICLE CLEARANCE SHALL BE PROVIDED ON PHASES THAT ARE TO BE TERMINATED BY PRE-EMPTION DEMAND.
- EMERGENCY VEHICLE PRE-EMPTION SHALL OVERRIDE COORDINATION.
- CONFIRMATION STROBES SHALL BE ILLUMINATED WHENEVER ANY EMERGENCY VEHICLE PREEMPTION GREEN IS ON.

PREEMPTION ASSEMBLY DETAIL

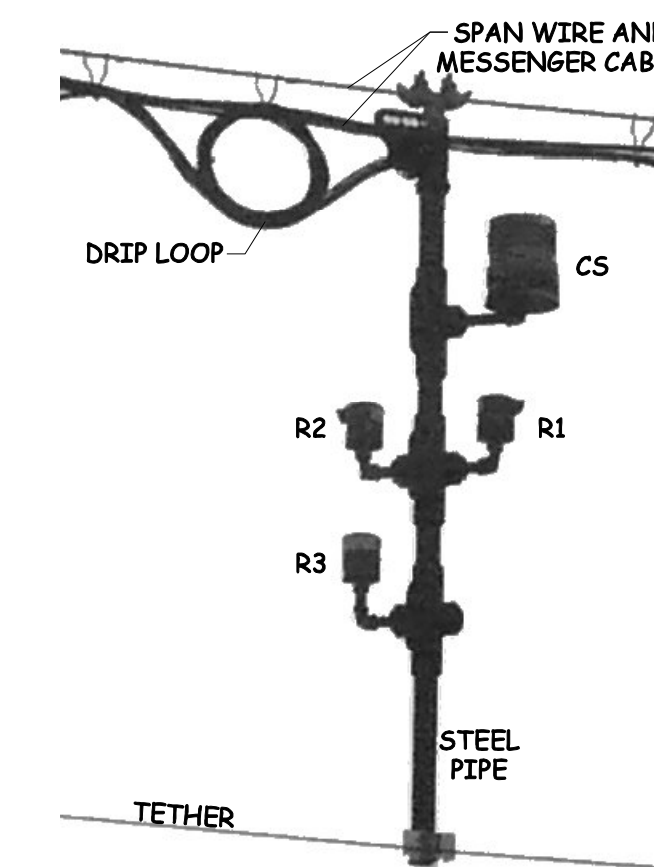

PLAN

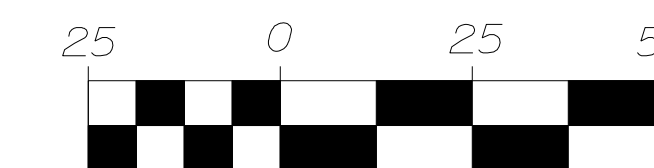

SCALE

STATE OF MAINE
DEPARTMENT OF TRANSPORTATION
AC-STP-1911(900)X
WIN
1911900

PROJ. MANAGER	B. KEEZER	BY	DATE
DESIGN-DETAILED	M. GRAHAM	M. GRAHAM	4/16/12
CHECKED-REVIEWED	J. ROBERT	C. BOBBAY	4/24/12
DESIGN-DETAILED			
DESIGN-DETAILED			
REVISIONS 1			
REVISIONS 2			
REVISIONS 3			
REVISIONS 4			
FIELD CHANGES			

PLEASANT STREET
UNION STREET
TRAFFIC SIGNAL PLAN

SHEET NUMBER
11
OF 16

Date: 4/26/2012

Username: VHB

Division:

Filename: ... \planset\012_52167005G04A.dgn

LIST OF MAJOR ITEMS

EQUIPMENT AND WORK ITEMS 643.71	QUANTITY
FURNISH AND INSTALL NEW NEMA TS2, TYPE 2 ETHERNET EQUIPPED CONTROLLER WITH LATEST SOFTWARE UPGRADE IN EXISTING CONTROLLER CABINET.	1
FURNISH AND INSTALL NEW 16-CHANNEL ETHERNET EQUIPPED ENHANCED MALFUNCTION MANAGEMENT UNIT IN CONFLICT MONITOR MODE	1
FURNISH AND INSTALL ONE-WAY, 3-SECTION, 12-INCH ASTROBRACKET MOUNTED TRAFFIC SIGNAL HEAD	1
BRACKET MOUNTED 16 x 18 INCH COUNTDOWN PEDESTRIAN SIGNAL HEAD PAINTED BLACK. INDICATION SHALL BE ENERGY EFFICIENT, 6ELCORE 6T1 LED OR APPROVED EQUAL	6
ADA COMPLIANT ACCESSIBLE PEDESTRIAN SIGNAL (APS) PUSH BUTTON WITH R10-3e INFORMATIONAL SIGN	2
R10-3e INFORMATIONAL SIGNS	3
FURNISH AND INSTALL ENVIRONMENTALLY HARDENED ETHERNET SWITCH	1
FURNISH AND INSTALL GENERATOR TRANSFER SWITCH	1
IMPLEMENT LOCAL AND SYSTEM TIMING	-

THE LISTED QUANTITIES ARE APPROXIMATE AND ARE FURNISHED FOR INFORMATION ONLY.

SIGNAL HEAD DATA

EXISTING	PROPOSED	
A1,A2,B1,B2,C1,C2	C3	P1-P6
12" LED LENS	12" LED LENS	16" x 18" LED PEDESTRIAN SIGNAL

F&I NEW ETHERNET EQUIPPED TS2 TYPE 2 CONTROLLER WITH LATEST SOFTWARE UPGRADE, ETHERNET EQUIPPED MANAGEMENT MALFUNCTION UNIT/CONFLICT MONITOR AND GENERATOR TRANSFER SWITCH IN EXISTING CONTROLLER CABINET.

IMPLEMENT LOCAL AND SYSTEM TIMING PLANS.

PROPOSED PHASING SEQUENCE

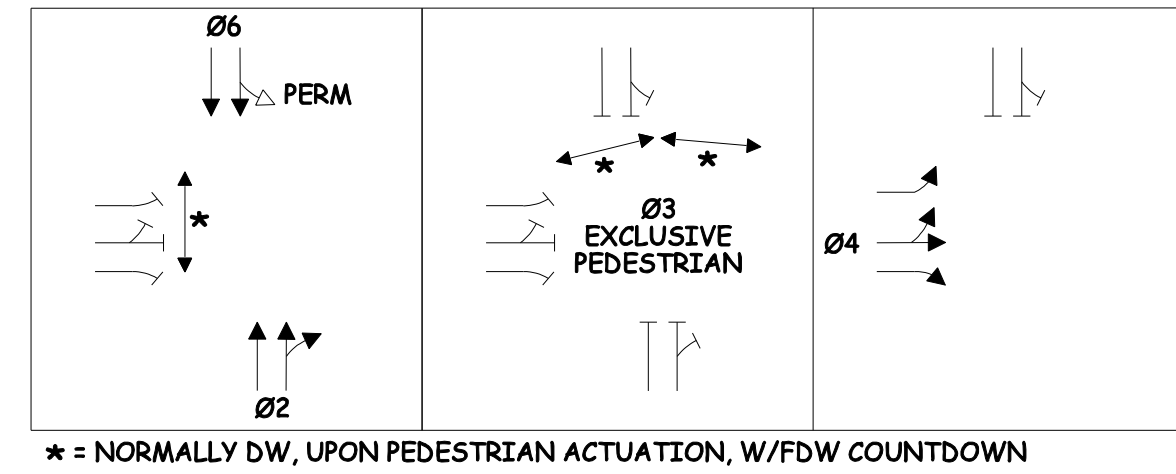

EMERGENCY VEHICLE PRE-EMPTION OPERATION

ID	PREEMPT ASSIGNMENT	RECEIVER PRIORITY	ACTIVE PHASE
	1		FIRE STATION
R1	2	1	Ø6
R2	3	2	Ø2
R3	4	3	Ø4

EMERGENCY VEHICLE PRE-EMPTION NOTES:

- EMERGENCY VEHICLE PRE-EMPTION SIGNALS SHALL BE TRANSMITTED BY OPTICAL EMITTERS (PROVIDED BY OTHERS) MOUNTED IN EMERGENCY VEHICLES AND RECEIVED BY OPTICAL DETECTORS LOCATED AT THE INTERSECTION.
- PRE-EMPTION SIGNALS SHALL BE SERVICED ON A PRIORITY BASIS WITH RECEIVERS ASSIGNED DESCENDING PRIORITIES (1 = HIGHEST, 3 = LOWEST)
- IN RESPONSE TO A PRE-EMPTION SIGNAL RECEIVED AT AN INTERSECTION BY AN OPTICAL DETECTOR, THE CONTROLLER SHALL HOLD OR ADVANCE TO AND HOLD THE EMERGENCY ACTIVE PHASE GREEN FOR A MINIMUM OF 10 SECONDS OR UNTIL THE PRE-EMPTION SIGNAL CEASES. THE CONTROLLER SHALL THEN TIME PRE-EMPTION PHASE CLEARANCE (4.0 SECONDS YELLOW AND 2.5 SECONDS ALL RED) AND SERVICE SUBSEQUENT EMERGENCY ACTIVE PHASES AS NECESSARY. AT THE COMPLETION OF THE PRE-EMPTION CYCLE, THE CONTROLLER SHALL TIME THE PRE-EMPTION CLEARANCE AND RESUME NORMAL SIGNAL OPERATION.
- MINIMUM GREEN AND NORMAL VEHICLE CLEARANCE SHALL BE PROVIDED ON PHASES THAT ARE TO BE TERMINATED BY PRE-EMPTION DEMAND.
- EMERGENCY VEHICLE PRE-EMPTION SHALL OVERRIDE COORDINATION.
- CONFIRMATION STROBES SHALL BE ILLUMINATED WHENEVER ANY EMERGENCY VEHICLE PREEMPTION GREEN IS ON.

COORDINATION CYCLE/SPLIT/OFFSET SCHEDULE

ALL ENTRIES IN SECONDS

	PLAN 1	PLAN 2	PLAN 3
CYCLE LENGTH	75	80	90
OFFSET (END GRN)	33	28	1
COORDINATED Ø	2	2	2
SPLIT TIME Ø1	0	0	0
SPLIT TIME Ø2	31	31	35
SPLIT TIME Ø3	22	22	22
SPLIT TIME Ø4	22	27	33
SPLIT TIME Ø5	0	0	0
SPLIT TIME Ø6	31	31	35
SPLIT TIME Ø7	22	22	22
SPLIT TIME Ø8	22	27	33

COORDINATION NOTES:

- OFFSET IS REFERENCED TO THE END OF THE COORDINATED PHASE.
- COORDINATION TO OPERATE BY TIME-OF-DAY (SEE SHEET 2 FOR DAY PLAN SETTINGS).
- TRAFFIC SIGNAL CONTROLLER SHALL BE SET FOR STOP TIME IN WALK TO ON.
- PHASES 7 AND 8 ARE DUMMY PHASES TO BE SET WITH SPLIT TIMES FOR NTCP COMPLIANCE.

DETECTOR SCHEDULE

PLAN ID	STREET	DIRECTION	LANE	Ø	DETECTOR				DETECTOR CARD IN VEHICLE DETECTION RACK				INDUCTANCE		CONTINUITY		RESISTANCE	
					TYPE	SLOT NO.	DETECTOR NO.	CHANNEL	PRIOR	PRESENT	PRIOR	PRESENT	PRIOR	PRESENT	PRIOR	PRESENT		
1																		
2																		
3																		
4																		
5																		
6																		
7																		
8																		
9																		
10																		
11																		
12																		

DETECTOR NOTES:

CONTRACTOR SHALL COMPLETE THE DETECTOR SCHEDULE FOR RECORD OF DETECTOR PROGRAMMING INTO THE TRAFFIC SIGNAL CONTROLLER.

RECORD FIELD MEASUREMENTS HERE

INTERSECTION:
PLEASANT STREET / MAINE STREET
SIGNAL GROUP:
1
LOCATION / PROPOSED DROP:
5

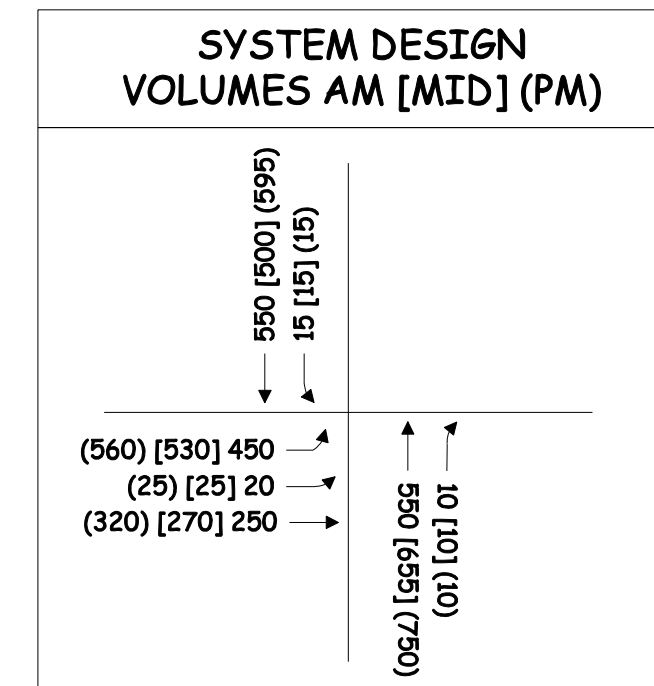

DAILY & WEEKLY COORDINATION PROGRAM

	MON-FRI	SAT-SUN
FREE OPERATIONS	0000 - 0730 0900 - 1100 1730 - 2400	0000 - 1100 1730 - 2400
PLAN 1 75 SECS MORNING PEAK	0730 - 0900	-
PLAN 2 80 SECS MIDDAY/EVENING PEAK	1100 - 1730	1600 - 1730
PLAN 3 90 SECS SATURDAY PEAK	-	1100 - 1600

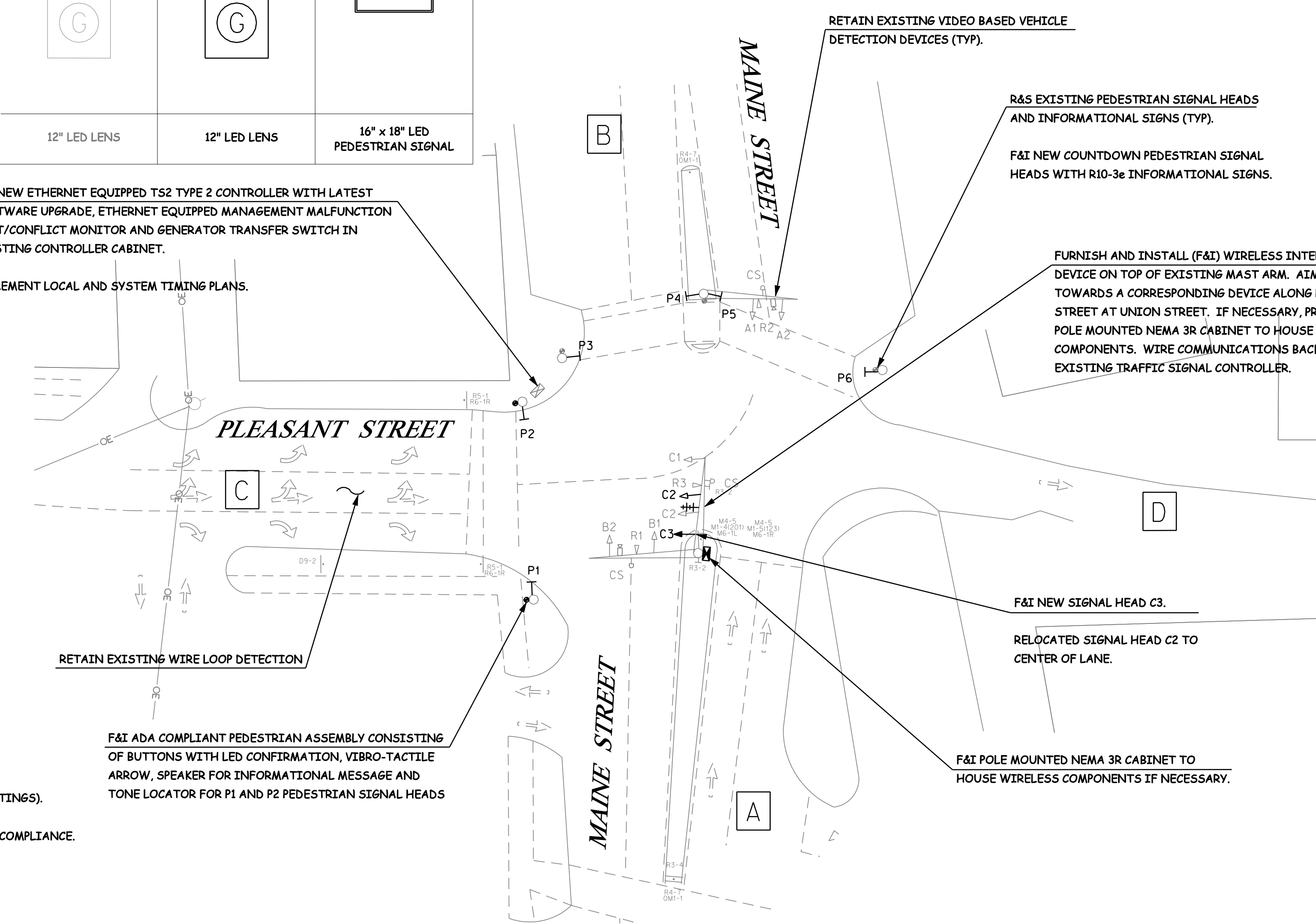
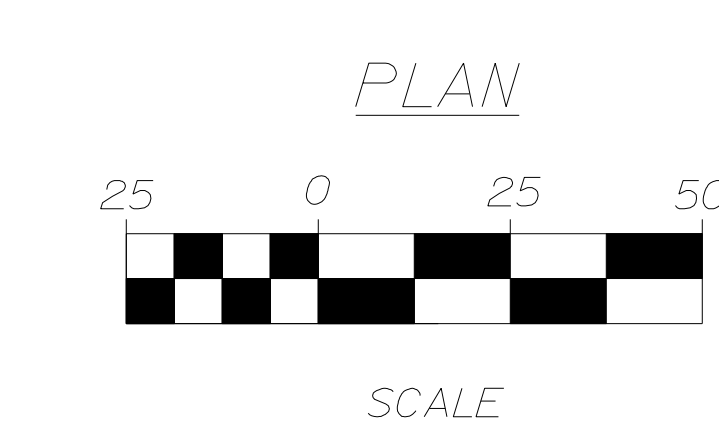

Date: 4/26/2012

Username: VHB

Division:

Filename: ... \s\planset\014_52167005G05.dgn

STATE OF MAINE
DEPARTMENT OF TRANSPORTATION
AC-STP-1911(900)X
WIN 1911900

PROJECT: PLEASANT STREET MAINE STREET
TRAFFIC SIGNAL PLAN

SHEET NUMBER: 12 OF 16

DATE: 4/16/12
BY: M. GRAHAM
CHECKED: J. ROBERT
DESIGN: M. GRAHAM
REVISIONS: 1, 2, 3, 4

INTERSECTION BASE PLAN WAS DIGITIZED BY VHB FROM AERIAL PHOTOGRAPHY AND OVERLAY OF EATON TRAFFIC ENGINEERING INTERSECTION IMPROVEMENT PLAN DATED JANUARY 2001. SUPPLEMENTAL INFORMATION WAS OBTAINED BY VHB THROUGH FIELD REVIEWS AND INVENTORY CONDUCTED BY MAINE TRAFFIC RESOURCES AS A SUBCONSULTANT TO VHB ON NOVEMBER 4, 2011 AND WITH FOLLOW-UP BY VHB ON NOVEMBER 18, 2011. RIGHT-OF-WAY INFORMATION IS NOT APPLICABLE GIVEN ALL WORK IS TO BE REPLACEMENT BASED.

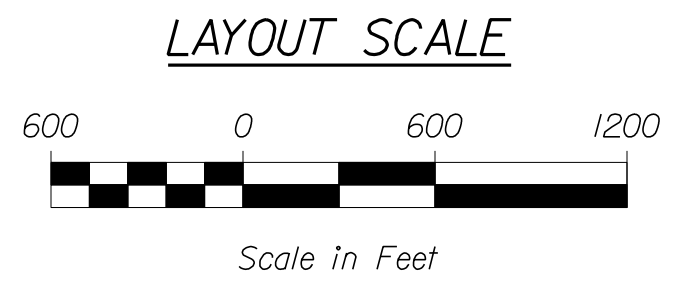
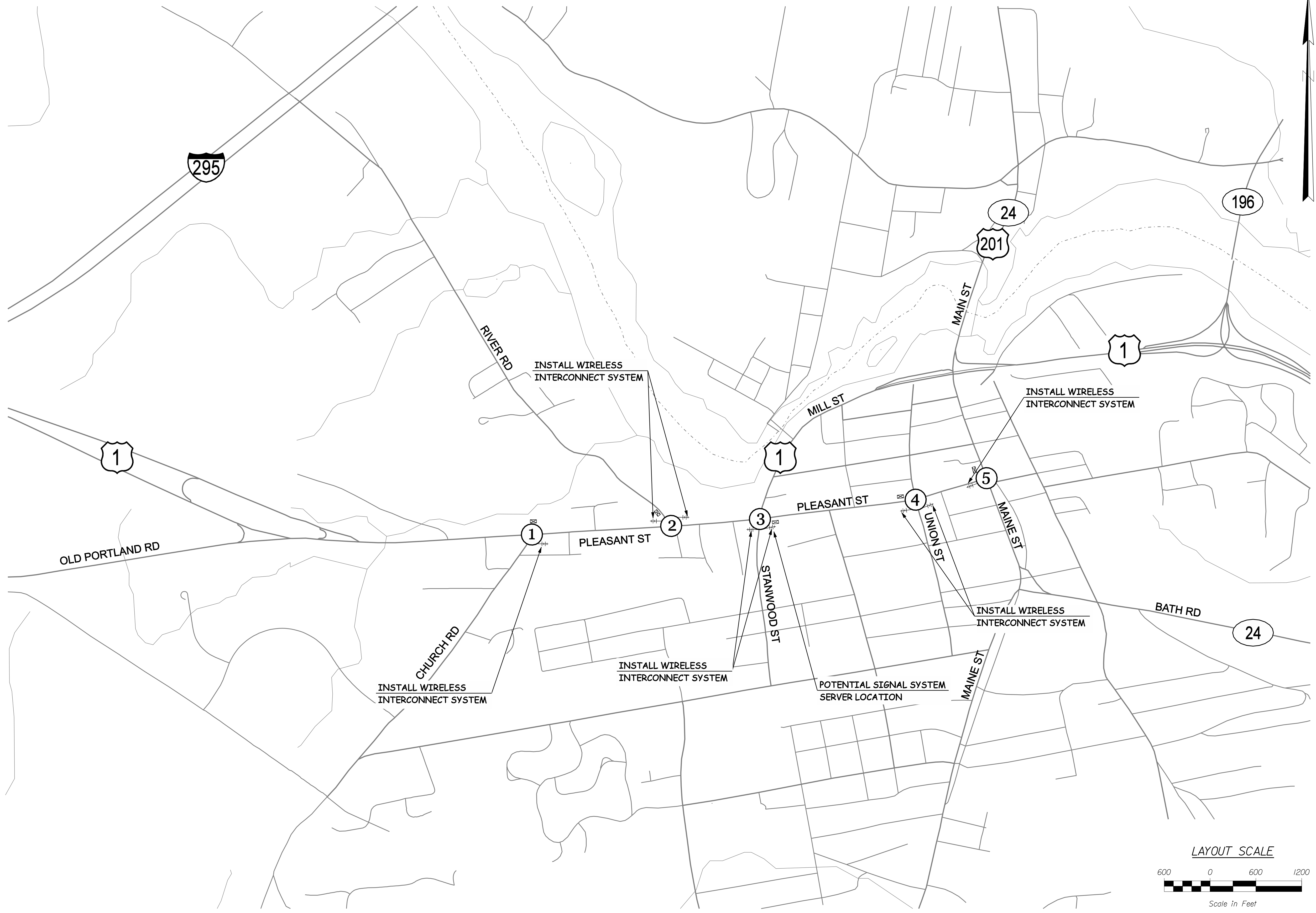

STATE OF MAINE
 DEPARTMENT OF TRANSPORTATION
 AC-STP-1911(900)X
 WIN
 1911900

PROJ. MANAGER	B. KEEZER	DATE
DESIGN-DETAILED	M. GRAHAM	4/16/12
CHECKED-REVIEWED	J. ROBERT	4/24/12
DESIGN-2-DETAILED		
DESIGN-3-DETAILED		
REVISIONS 1		
REVISIONS 2		
REVISIONS 3		
REVISIONS 4		
FIELD CHANGES		

PLEASANT STREET
 INTERCONNECT PLAN

SHEET NUMBER
 13
 OF 16

**PLAN 1
75/150 SECOND BACKGROUND CYCLE**

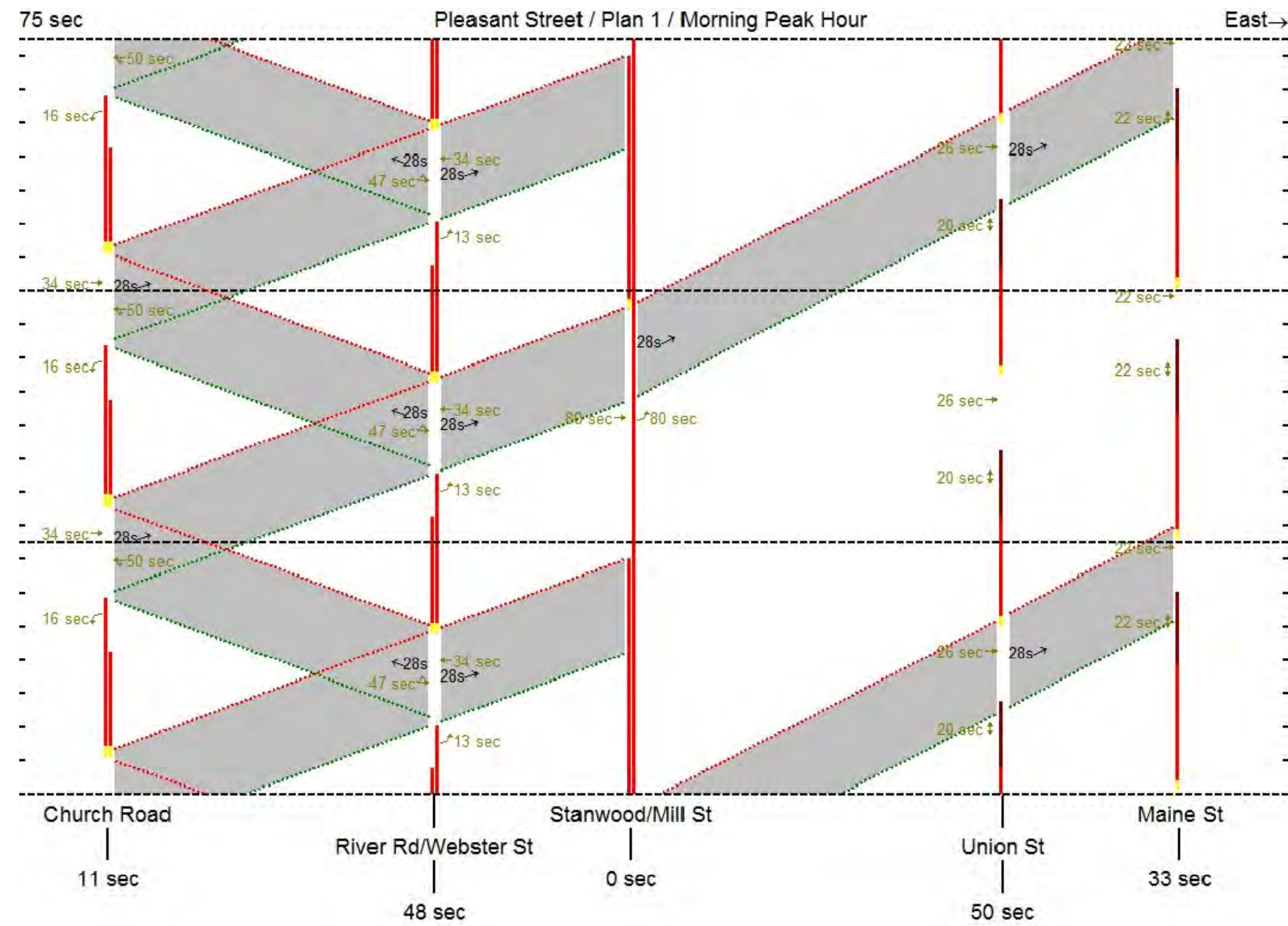

**PLAN 2
80/160 SECOND BACKGROUND CYCLE**

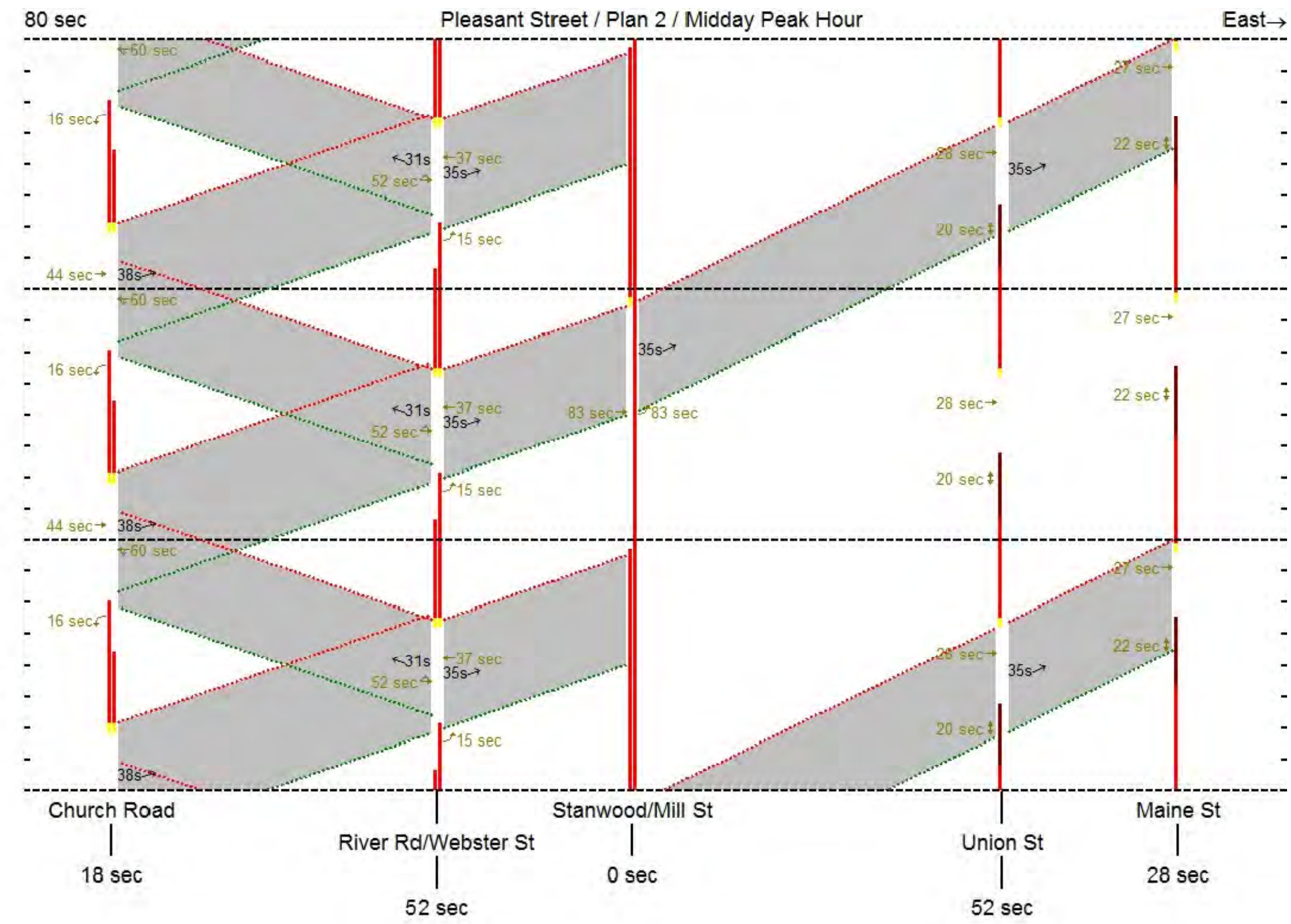

**PLAN 3
90/180 SECOND BACKGROUND CYCLE**

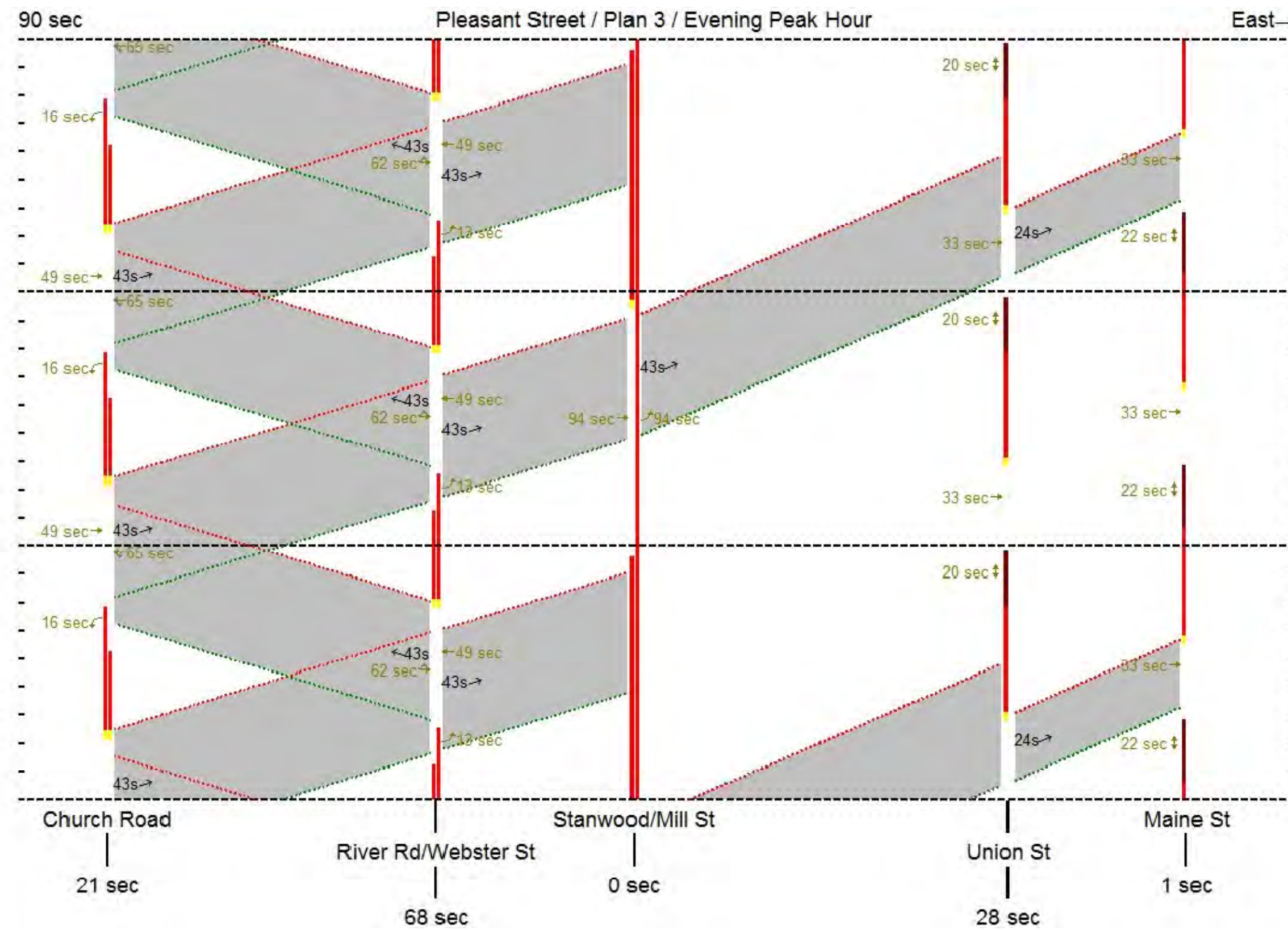

Date: 4/26/2012

Username: VHB

Division: ... \ts\planset\016_5216700TSD1.dgn

STATE OF MAINE
DEPARTMENT OF TRANSPORTATION
AC-STP-1911(900)X
WIN
1911900

PROJ. MANAGER	B. KEEZER	DATE	
DESIGN-DETAILED	M. GRAHAM	4/16/12	
CHECKED-REVIEWED	J. ROBERT	4/24/12	
DESIGN-DETAILED	C. BOBBAY		
DESIGN-DETAILED			
REVISIONS 1			
REVISIONS 2			
REVISIONS 3			
REVISIONS 4			
FIELD CHANGES			

PLEASANT STREET

TIME SPACE DIAGRAMS

SHEET NUMBER

14

OF 16

Date: 5/29/2012

Username: VHB

Division:

Filename: ... \planset\008_5216700SC02B.dgn

TERMINAL CURB TYPE 1 - 7 FT - CIRCULAR		
POINT TO POINT	RADIUS	LENGTH
8 TO 9	35.0'	7.0'
10 TO 11	35.0'	7.0'

TERMINAL CURB TYPE 1 - 7 FT		
POINT TO POINT	RADIUS	LENGTH
1 TO 2	-	7.0'
3 TO 4	-	7.0'
6 TO 7	-	7.0'
13 TO 14	-	7.0'

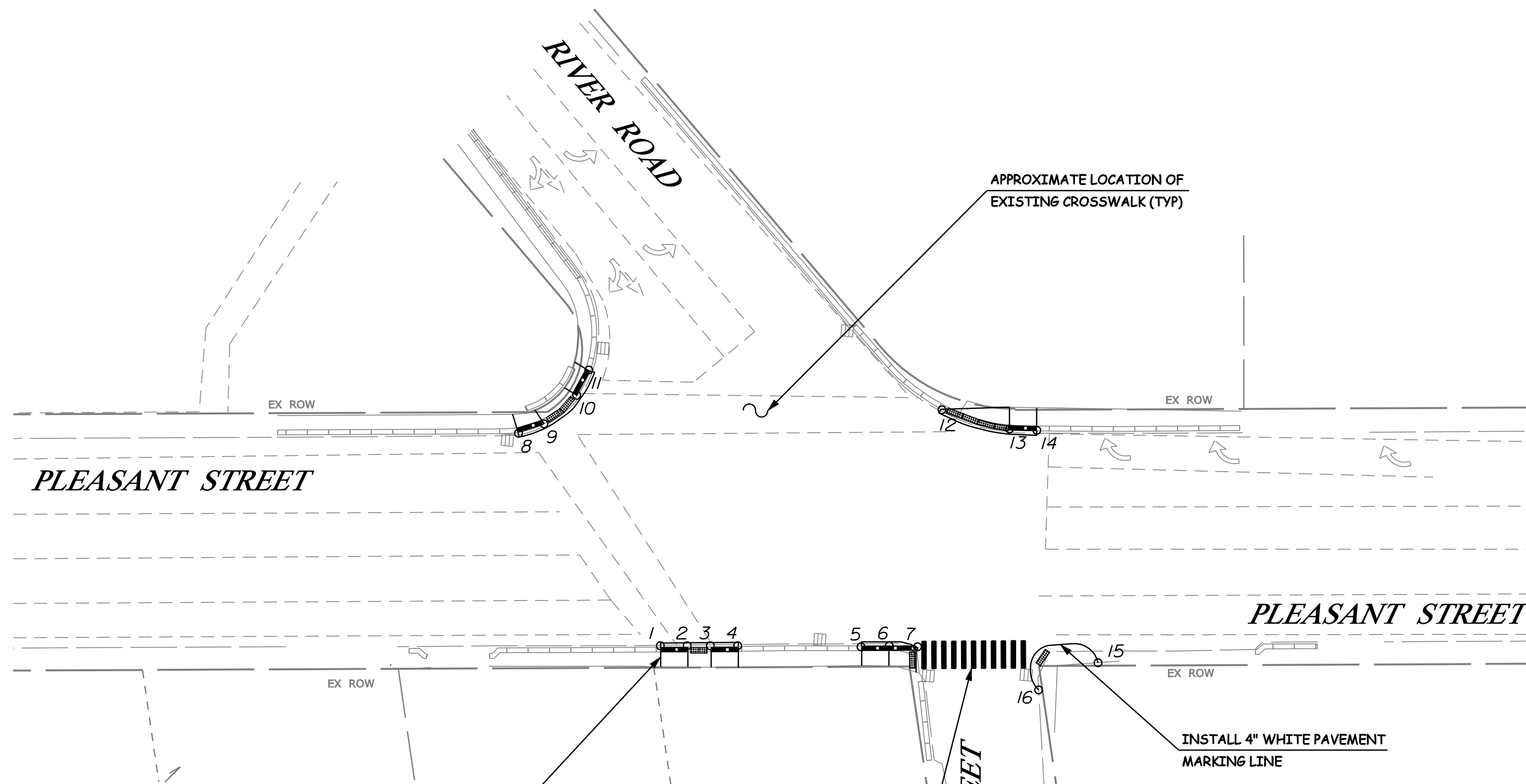

LIST OF MAJOR ITEMS	
EQUIPMENT AND WORK (ITEM XXX.YYZ)	QUANTITY
COMMON EXCAVATION (ITEM 203.20)	17 CY
HOT MIX ASPHALT, 9.5 MM NOMINAL MAXIMUM SIZE (SIDEWALKS, DRIVES, ISLANDS & INCIDENTALS) (ITEM 403.209)	4 TONS
REINFORCED CONCRETE SIDEWALK (ITEM 608.08)	42 SY
CURB RAMP DETECTABLE WARNING FIELD (ITEM 608.26)	90 SF
REGRADE SIDEWALK (ITEM 608.46)	50 SY
TERMINAL CURB TYPE 1 - 7 FEET (ITEM 609.237)	4
TERMINAL CURB TYPE 1 - 7 FEET CIRCULAR (ITEM 609.2371)	2
4" WHITE PAVEMENT MARKING LINE (ITEM 627.733)	30 LF
WHITE PAVEMENT AND CURB MARKING (ITEM 627.75)	77 SF

THE LISTED QUANTITIES ARE APPROXIMATE AND ARE FURNISHED FOR INFORMATION ONLY.

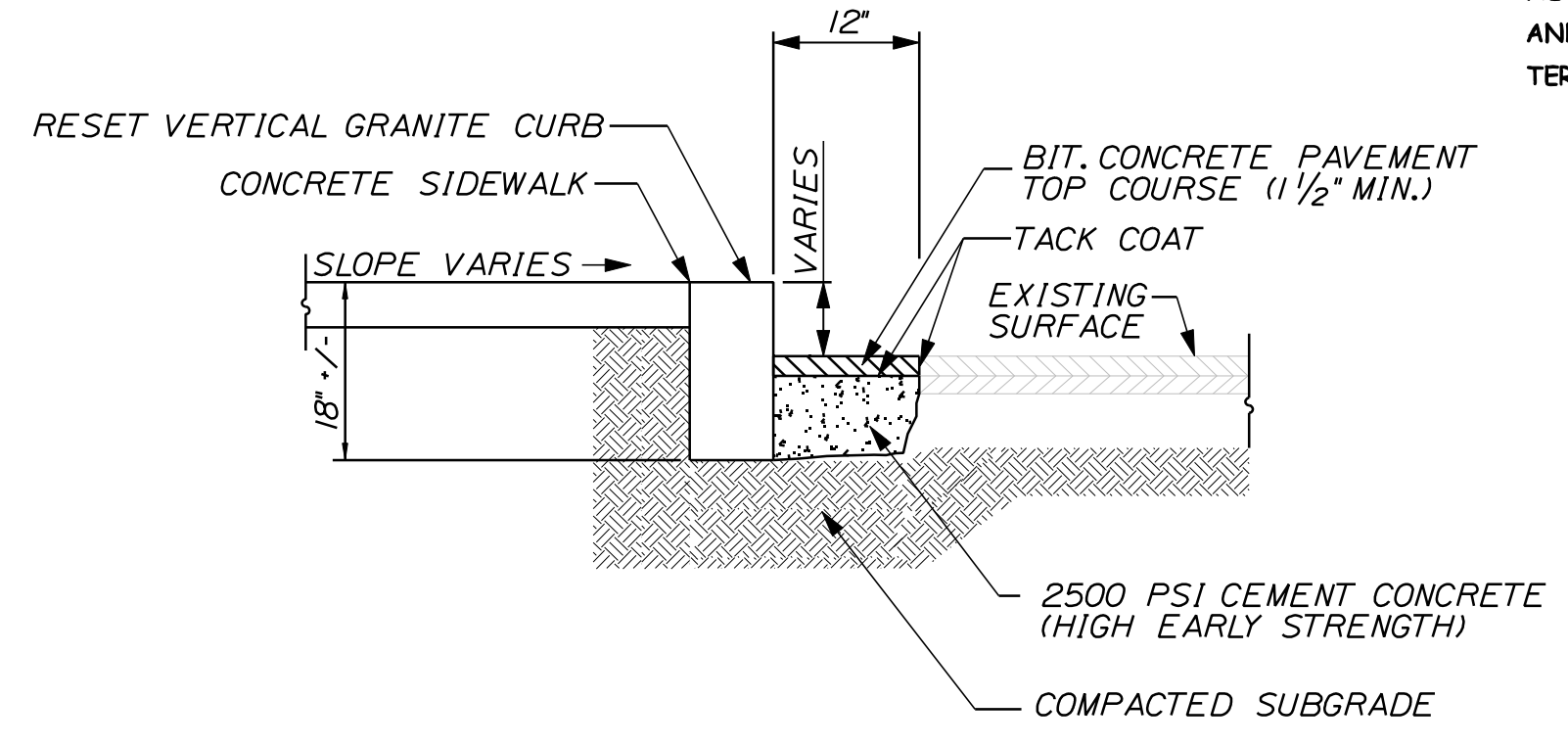

VERTICAL GRANITE CURB SET IN EXISTING PAVEMENT
PEDESTRIAN RAMP INSTALLATION
SEE MAINEDOT STANDARD DETAILS 609 & 801

INTERSECTION:
PLEASANT STREET / RIVER ROAD
SIGNAL GROUP:
1
LOCATION / PROPOSED DROP:
2

INTERSECTION BASE PLAN AND RIGHT-OF-WAY WAS PROVIDED BY MAINEDOT SURVEY WITH ADDITIONAL REFERENCE TO TY LIN INTERNATIONAL WITH HUNTER-BALLEW ASSOCIATES INTERSECTION IMPROVEMENT PLAN DATED 3/1/89. SUPPLEMENTAL INFORMATION WAS OBTAINED BY VHB THROUGH FIELD REVIEWS AND INVENTORY CONDUCTED BY MAINE TRAFFIC RESOURCES AS A SUBCONSULTANT TO VHB ON NOVEMBER 6, 2011 AND WITH FOLLOW-UP BY VHB ON NOVEMBER 18, 2011.

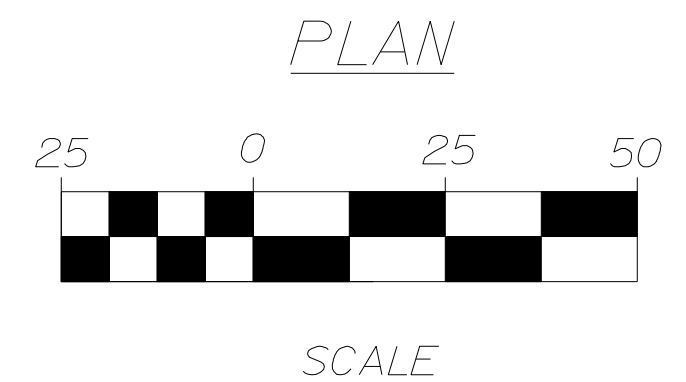
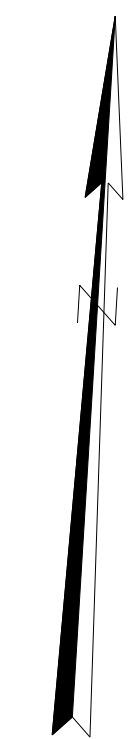

STATE OF MAINE DEPARTMENT OF TRANSPORTATION AC-STP-1911(900)X	WIN 1911900
SIGNATURE	P.E. NUMBER
DATE	DATE
BY M. GRAHAM C. BOBBAY	DATE 4/16/12 4/24/12
B. KEEZER	DATE
M. GRAHAM J. ROBERT	DATE
DESIGN-DETAILED	DATE
CHECKED-REVIEWED	DATE
DESIGN-DETAILED2	DATE
DESIGN-DETAILED3	DATE
REVISIONS 1	DATE
REVISIONS 2	DATE
REVISIONS 3	DATE
REVISIONS 4	DATE
FIELD CHANGES	DATE
PLEASANT STREET RIVER ROAD	CURB RAMP LAYOUT PLAN
SHEET NUMBER	15
OF 16	OF 16

TERMINAL CURB TYPE 1 - 7 FT		
POINT TO POINT	RADIUS	LENGTH
1 TO 2	-	7.0'

LIST OF MAJOR ITEMS

EQUIPMENT AND WORK (ITEM XXX.YYZ)	QUANTITY
COMMON EXCAVATION (ITEM 203.20)	17 CY
HOT MIX ASPHALT, 9.5 MM NOMINAL MAXIMUM SIZE (SIDEWALKS, DRIVES, ISLANDS & INCIDENTALS) (ITEM 403.209)	2 TONS
REINFORCED CONCRETE SIDEWALK (ITEM 608.08)	42 SY
CURB RAMP DETECTABLE WARNING FIELD (ITEM 608.26)	80 SF
REGRADING SIDEWALK (ITEM 608.46)	45 SY
TERMINAL CURB TYPE 1 - 7 FEET (ITEM 609.237)	1

THE LISTED QUANTITIES ARE APPROXIMATE AND ARE FURNISHED FOR INFORMATION ONLY.

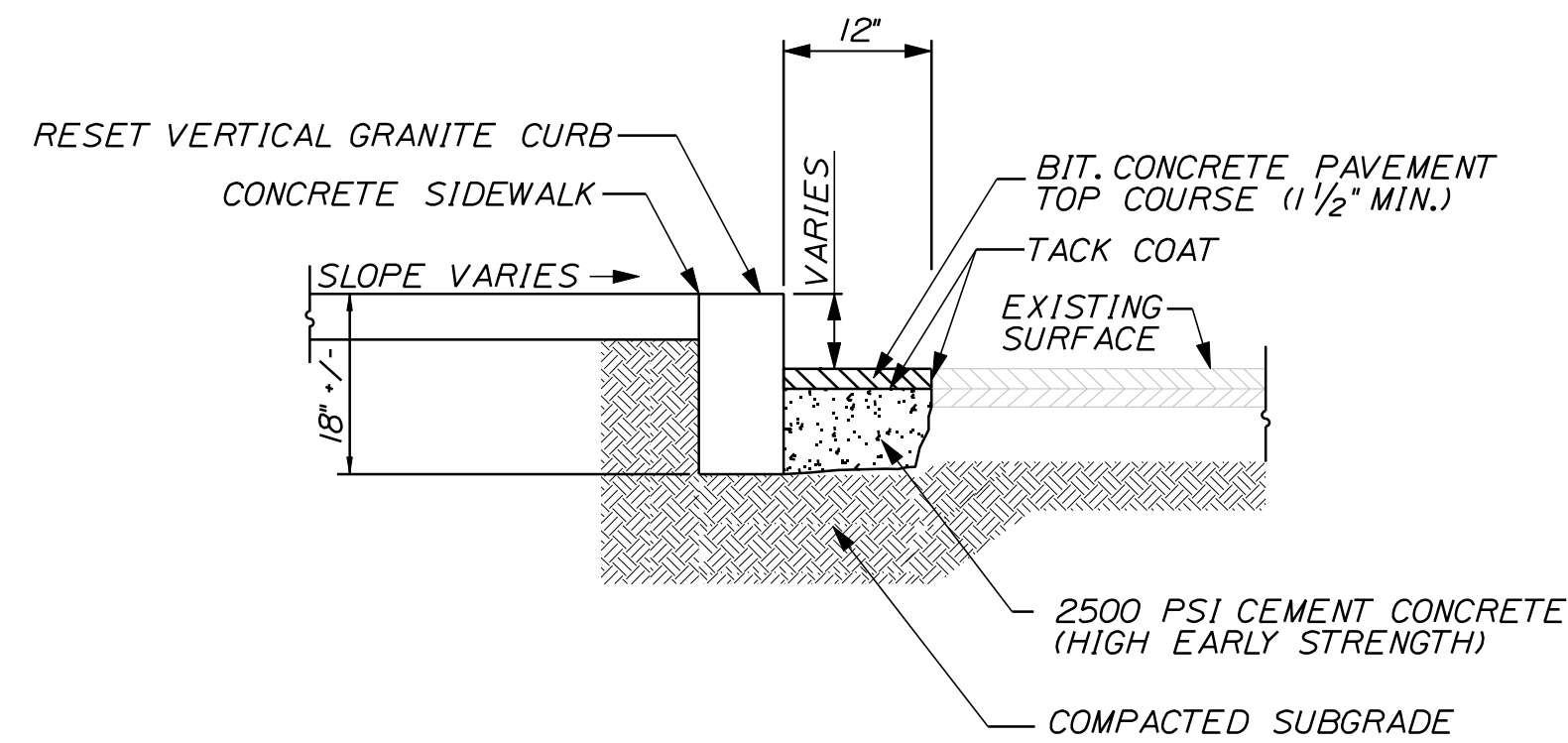
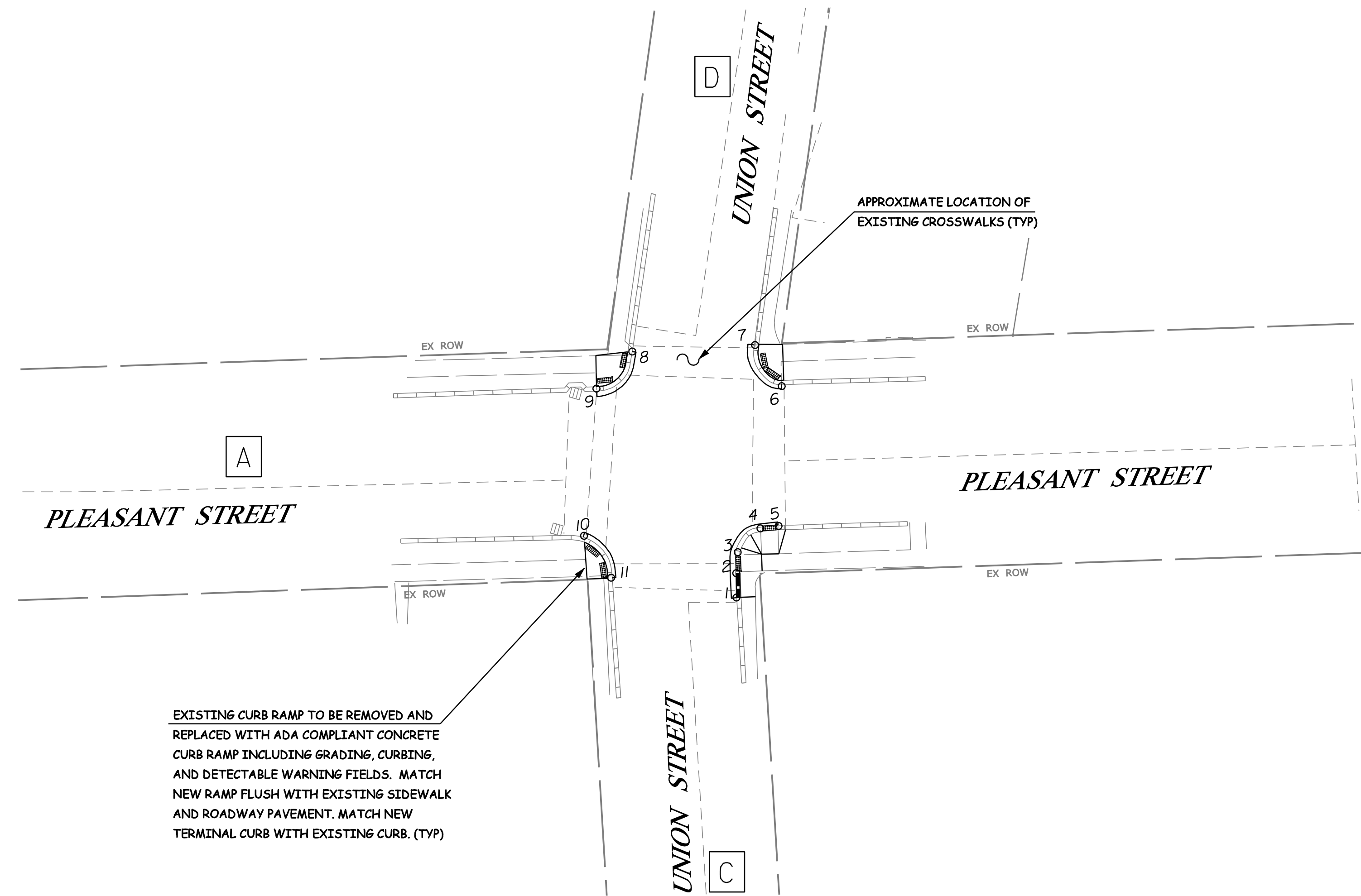

VERTICAL GRANITE CURB SET IN EXISTING PAVEMENT
PEDESTRIAN RAMP INSTALLATION
SEE MAINEDOT STANDARD DETAILS 609 & 801

INTERSECTION:
PLEASANT STREET / UNION STREET
SIGNAL GROUP:
1
LOCATION / PROPOSED DROP:
4

INTERSECTION BASE PLAN AND RIGHT-OF-WAY WAS PROVIDED BY MAINEDOT SURVEY. SUPPLEMENTAL INFORMATION WAS OBTAINED BY VHB THROUGH FIELD REVIEWS AND INVENTORY CONDUCTED BY MAINE TRAFFIC RESOURCES AS A SUBCONSULTANT TO VHB ON NOVEMBER 4, 2011 AND WITH FOLLOW-UP BY VHB ON NOVEMBER 18, 2011.

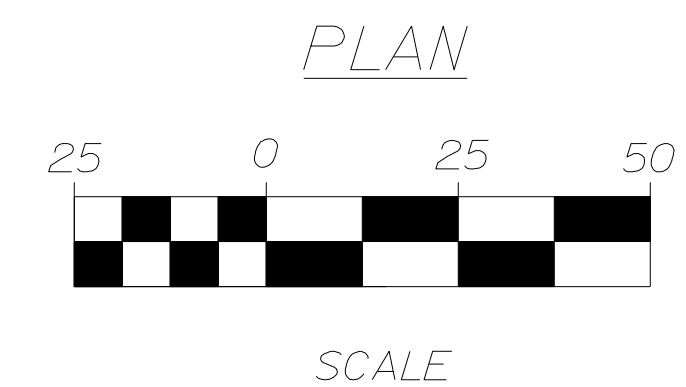
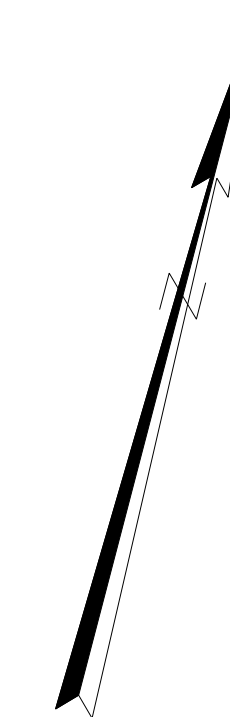

STATE OF MAINE
DEPARTMENT OF TRANSPORTATION
AC-STP-1911(900)X
WIN
1911900

PROJ. MANAGER	B. KEEZER	BY	DATE
DESIGN-DETAILED	M. GRAHAM	M. GRAHAM	4/16/12
CHECKED-REVIEWED	J. ROBERT	C. BOBBAY	4/24/12
DESIGN-DETAILED			
REVISIONS			
REVISIONS			
REVISIONS			
FIELD CHANGES			

PLEASANT STREET
UNION STREET
CURB RAMP LAYOUT PLAN

SHEET NUMBER

16

OF 16